

1282

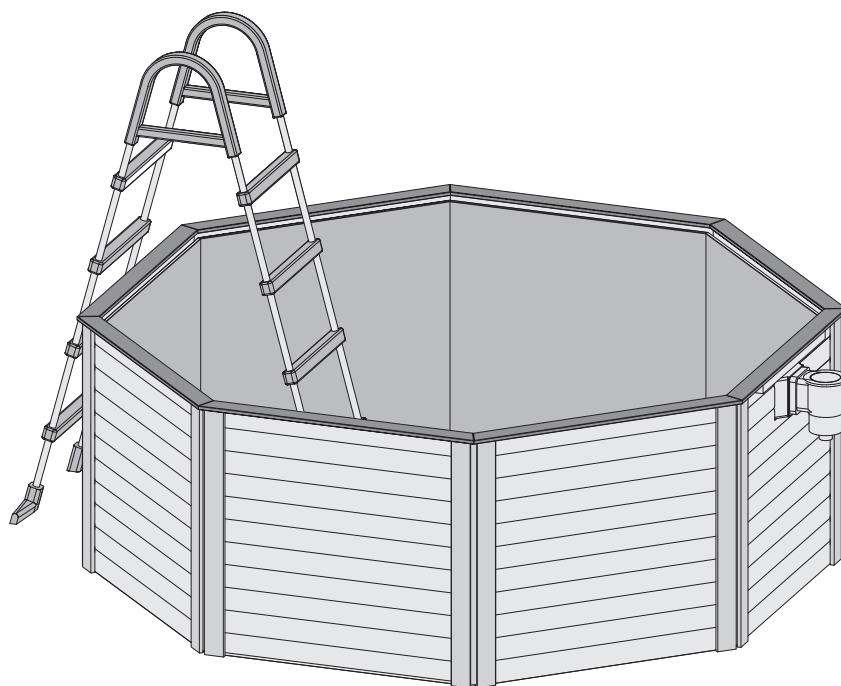

Das komplette
Farbangebot
finden Sie auf:



www.KARIBU-FARBENSHOP.de

-  **Aufbauanleitung**
-  **Building Instructions**
-  **notice de montage**
-  **montagehandleiding**
-  **Montagevejledning**
-  **Instrucciones de construcción**
-  **Istruzioni per il montaggio**
-  **Montážní návod**
-  **Navodila za sestavljanje**

Bitte bewahren Sie die Anleitung und den Garantieschein zur Seriennummer auf.

Vernichten Sie diese erst nach Ablauf der Garantiezeit.

Eventuelle Beanstandungen können mithilfe der Stückliste einfacher zugeordnet werden.

Beigelegte Dokumente

- Informationsheft
- Garantieschein zur Seriennummer
- Typenschild inkl. Warnhinweise (Sauna)
- ggf. Zubehör-Anleitungen in externen Paketen

*

-  Nicht im Lieferumfang enthalten
-  Not included
-  Non comprises dans la livraison
-  Niet bijgeleverd
-  No forman parte del suministro
-  Non incluso
-  V ceně není zahrnuto
-  Ikke inkluderet
-  Ni vključeno v obseg dobave









2

-  Nicht gebraucht
-  Not needed
-  Pas nécessaire
-  Niet nodig
-  No es necesario
-  Non necessario
-  Není nutná
-  Ikke nødvendigt
-  Ne uporabljajte

4

-  Fixiert vorübergehend
-  Fixed temporarily
-  Temporairement fixe
-  Tijdelijk vast
-  Temporalmente fijo
-  Temporaneamente fisso
-  Dočasně pevný
-  Midlertidigt rettet
-  Začasno popravi

1

-  Länge muss ermittelt und zugesagt werden
-  Length must be determined and sawn
-  La longueur doit être déterminée et sciée
-  De lengte moet worden bepaald en worden gezaagd
-  La longitud debe ser determinada y aserrada
-  La lunghezza deve essere determinata e segata
-  Délka musí být určena a rozřezána
-  Længden skal bestemmes og saves
-  Določiti je treba dolžino in jo odrezati po velikosti.

3

-  Mit Zubehör
-  With accessories
-  Avec accessoires
-  Met toebehoren
-  Con accesorios
-  Con accessori
-  S příslušenstvím
-  Med tilbehør
-  Z dodatki

5

-  Bestand vom Pool
-  Inventory of the pool
-  Inventaire de la piscine
-  Voorraad uit het zwembad
-  Stock de la piscina
-  Scorte dal pool
-  Zásoby z bazénu
-  Lager fra poolen
-  Zaloge iz bazena

 Vergleichen Sie zuerst die Material-liste mit Ihrem Paketinhalt! Bitte haben Sie Verständnis, dass Beanstandungen nur im nicht aufgebauten Zustand bearbeitet werden können!

 First compare the list of materials with your package contents! Please understand that complaints can be processed in the non-built status only!

 Commencez par comparer la liste du matériel avec le contenu de votre paquet! Sachez que nous traitons uniquement les réclamations concernant le matériel à l'état non monté!

 Vergelijk eerst de lijst van materialen met de inhoud van uw pakket! Reclamaties kunnen alleen in behandeling worden genomen zolang de onderdelen nog niet zijn gemonteerd!

 Start med at kontrollere materialelisten med indholdet af den leverede pakke! Vi gør venligst opmærksom på at reklamationer kun kan behandles for materialer som ikke er blevet bearbejdet!

 En primer lugar, compare la lista de material con el contenido del paquete. Rogamos entienda que las reclamaciones sólo pueden ser tramitadas antes de montar el objeto!

 Confrontate questa distinta materiali prima con il contenuto del pacchetto! Vi preghiamo di comprendere che eventuali reclami possono essere accolti solo prima del montaggio!

 Nejprve přezkontrolujte obsah balení podle materiálového listu! Mějte pochopení pro to, že případnou reklamaci se můžeme zabývat pouze tehdy, když díly nebudou smontované! Za pomoci tohoto seznamu můžete jednotlivé díly přiřadit k montážnímu návodu.

 Najprej primerajte zoznam materialov z vebino vašega paketa! Upoštevajte, da lahko pritožbe obravnavamo le v nesestavljenem stanju!

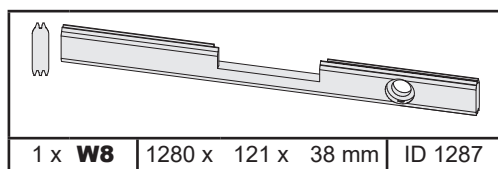
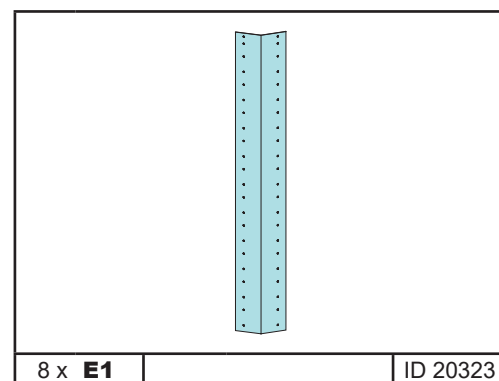
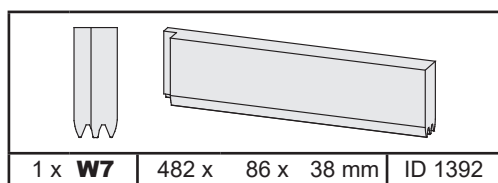
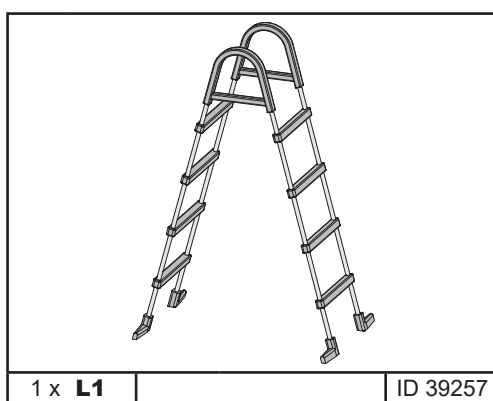
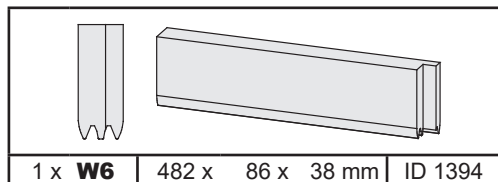
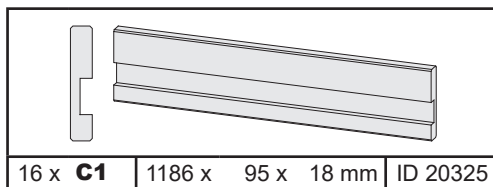
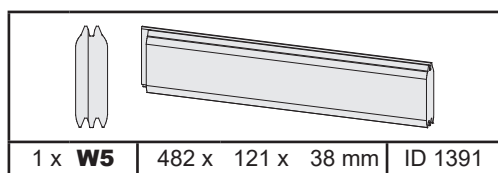
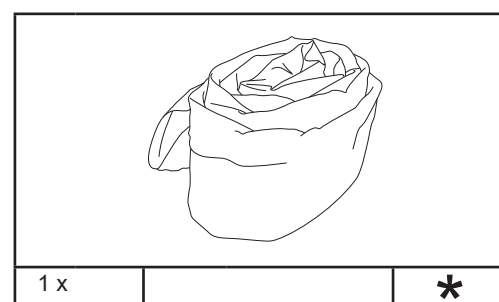
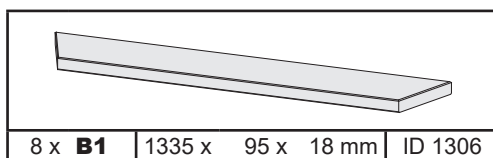
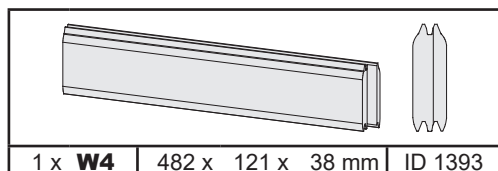
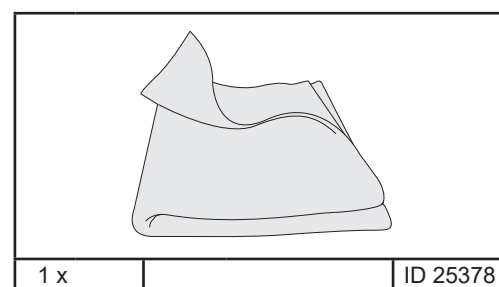
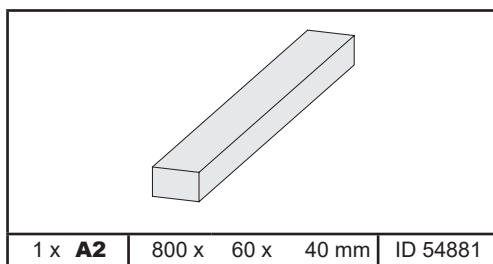
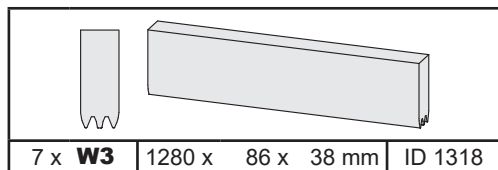
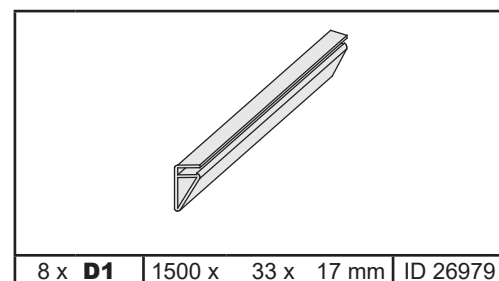
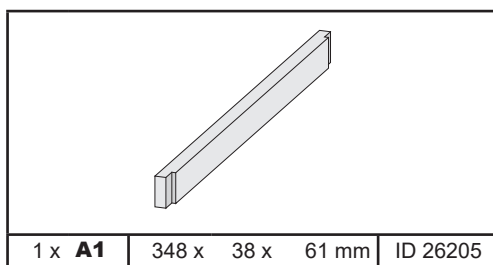
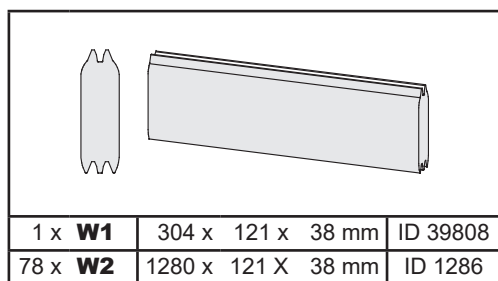
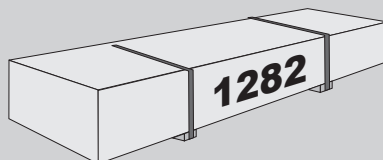

140 x	4 x 35 mm	ID 3687

5 x	4 x 16 mm	ID 47581

55 x	4 x 35 mm	ID 39398
5 x	6 x 80 mm	ID 39397

360 x	6 x 35 mm	ID 20324

40 x	5 x 50 mm	ID 57137

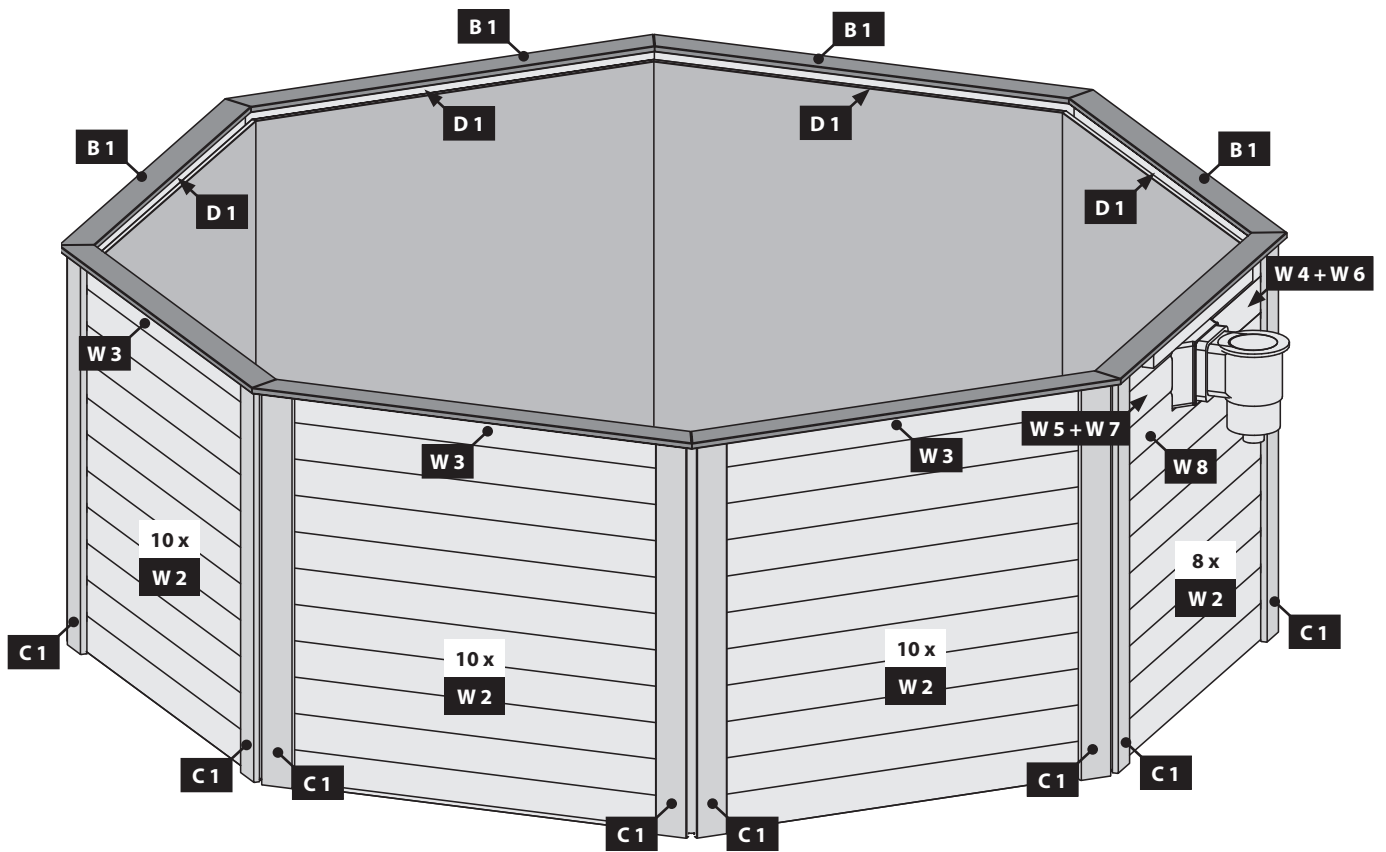



 Um das Ertrinken von Kindern zu verhindern, wird empfohlen, den Zugang zum Schwimmbecken mit einer Schutzeinrichtung zu sichern!

 For at forhindre drukning af børn anbefales det at sikre adgang til swimmingpoolen med en beskyttelsesanordning!

 Da bi preprečili utopitev otrok, priporočamo, da dostop do bazena zavarujete z varnostno napravo!

 To prevent the drowning of children, it is recommended to secure access to the swimming pool with a protective device!

 Para evitar que los niños se ahoguen, se recomienda asegurar el acceso a la piscina con un dispositivo de protección.



 Pour éviter la noyade des enfants, il est recommandé de sécuriser l'accès à la piscine avec un dispositif de protection!



 Per prevenire l'annegamento dei bambini, si consiglia di proteggere l'accesso alla piscina con un dispositivo di protezione!



 Om verdrinking van kinderen te voorkomen, is het aan te raden om de toegang tot het zwembad te beveiligen met een beschermend apparaat!

 Aby se zabránilo utopení dětí, doporučuje se zajistit přístup k bazénu s ochranným zařízením!









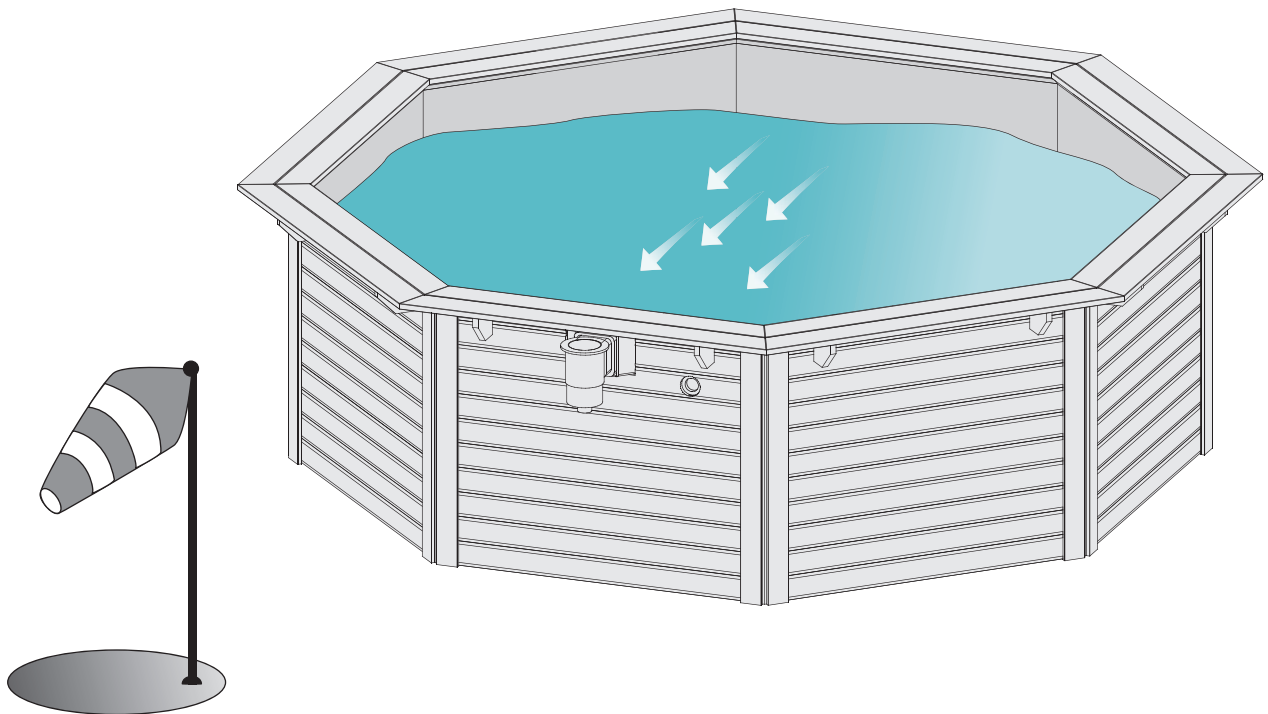

 Nicht im Lieferumfang enthalten
 Niet bijgeleverd
 Not included

 Non comprises dans la livraison
 No forman parte del suministro
 Non incluso

 V ceně není zahrnuto
 Ikke inkluderet
 Ni vključeno v obseg dobave.



 Skimmer in Hauptwindrichtung einbauen
 installeren skimmers in de belangrijkste windrichting
 installing skimmers in the main wind direction
 l'installation de récupérateurs dans la direction principale du vent
 la instalación de skimmers en la dirección dominante del viento
 installazione skimmer nella direzione principale del vento
 instalací sběračky v hlavním směru větru
 Installer skimmer i hovedvindretningen
 Skimmer namestite v smeri glavnega vetra

4x

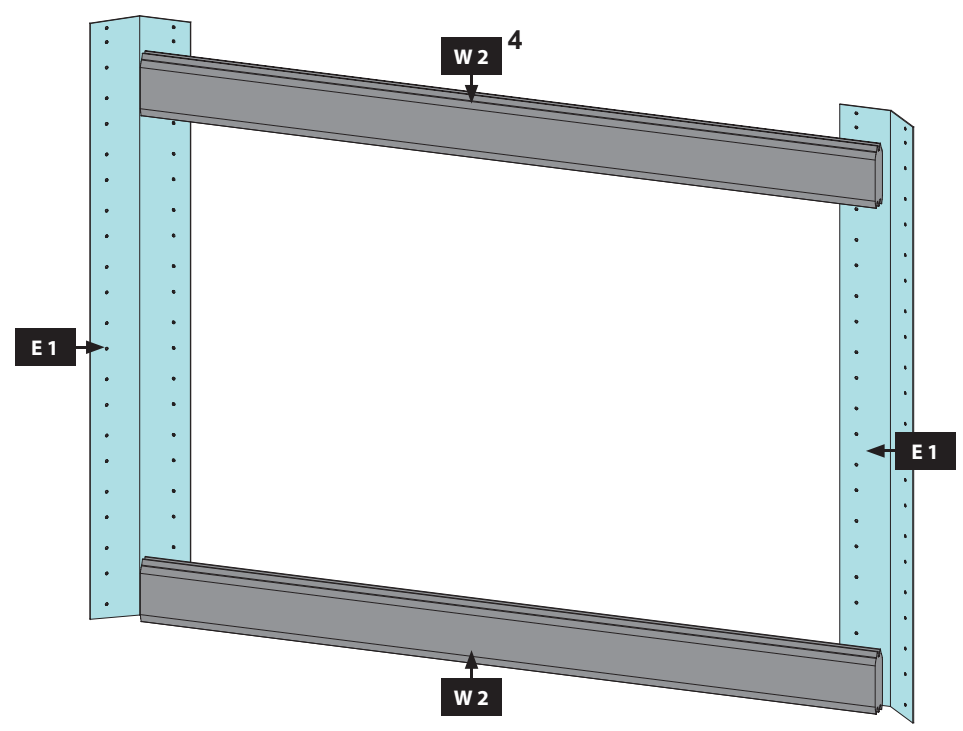
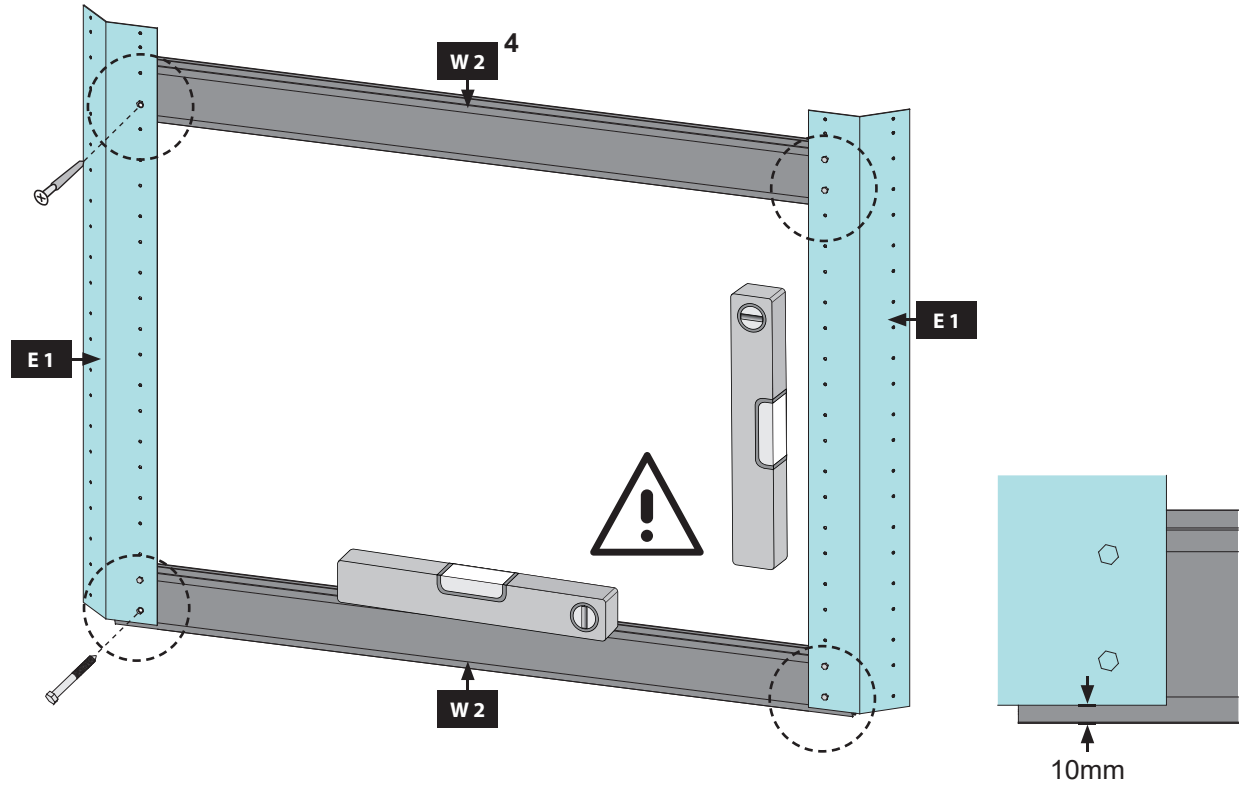
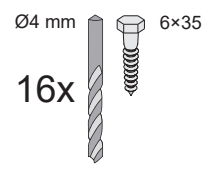
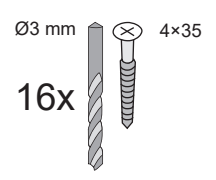

-  Rückseite
-  back
-  arrière
-  achterkant
-  bagtil
-  trasero
-  posteriore
-  zadní
-  Zadnji ovitek

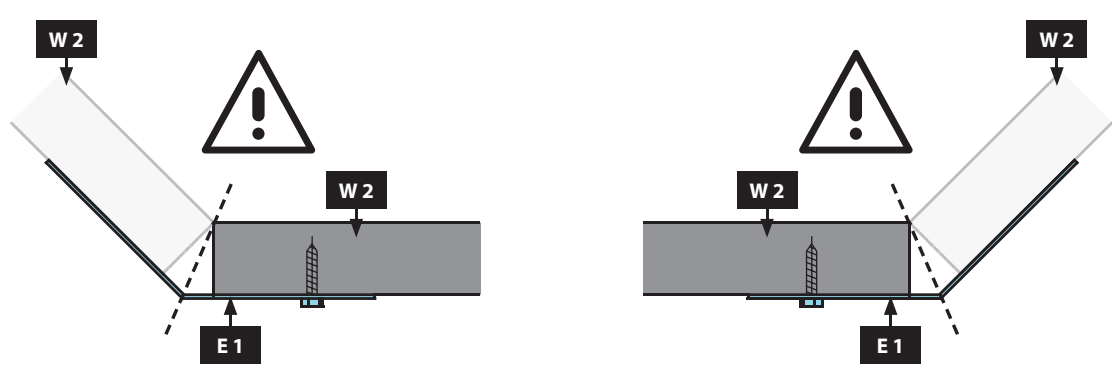

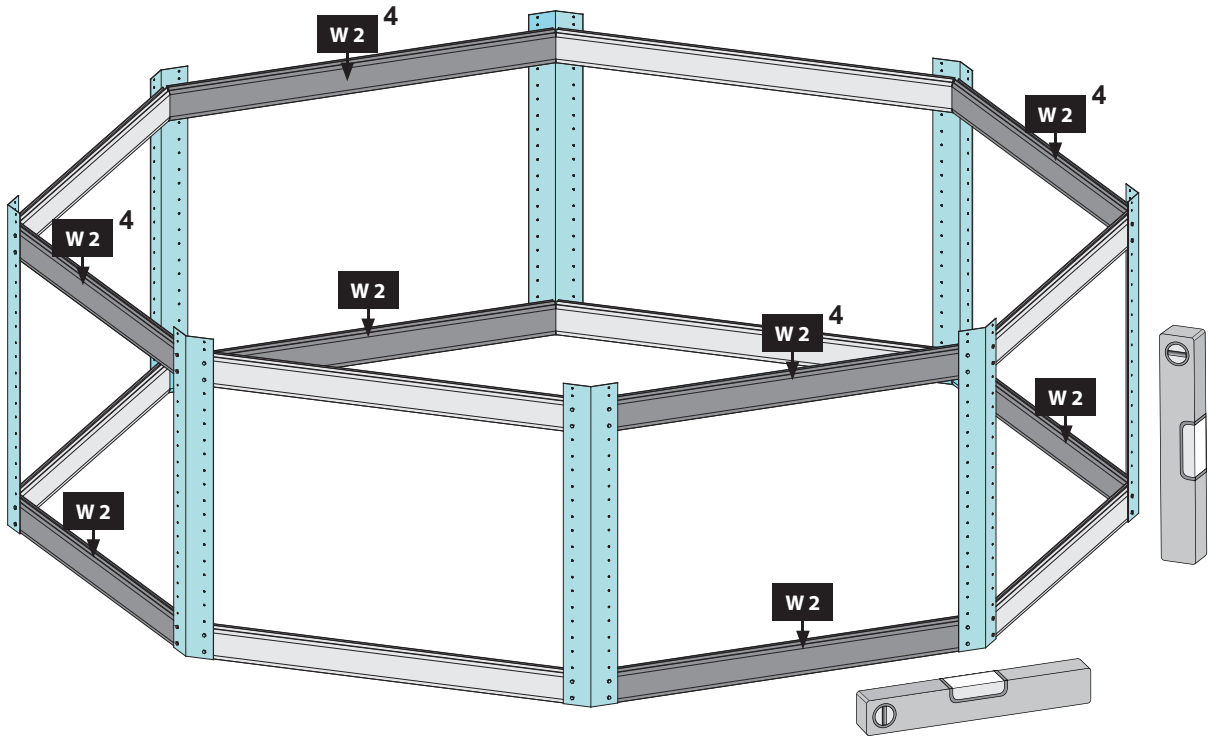

- Ø3 mm 4x35
- 16x
- Ø4 mm 6x35
- 16x

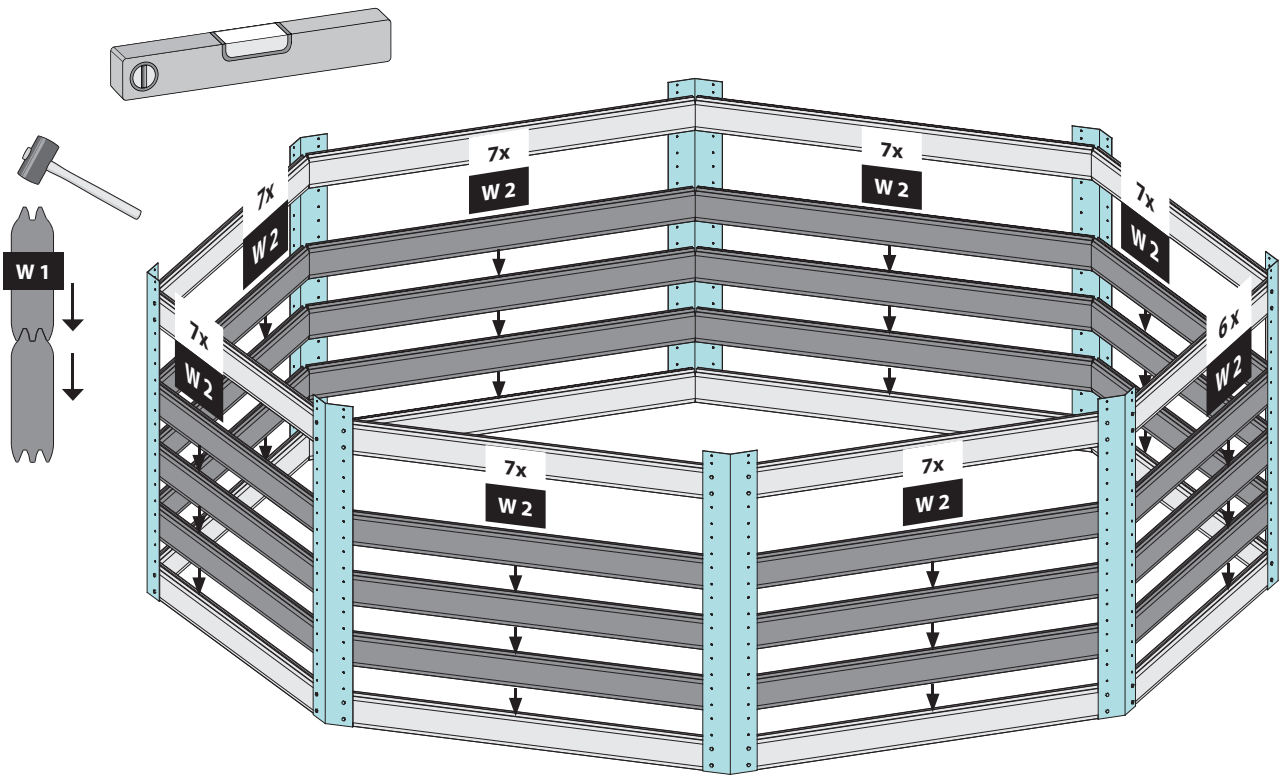
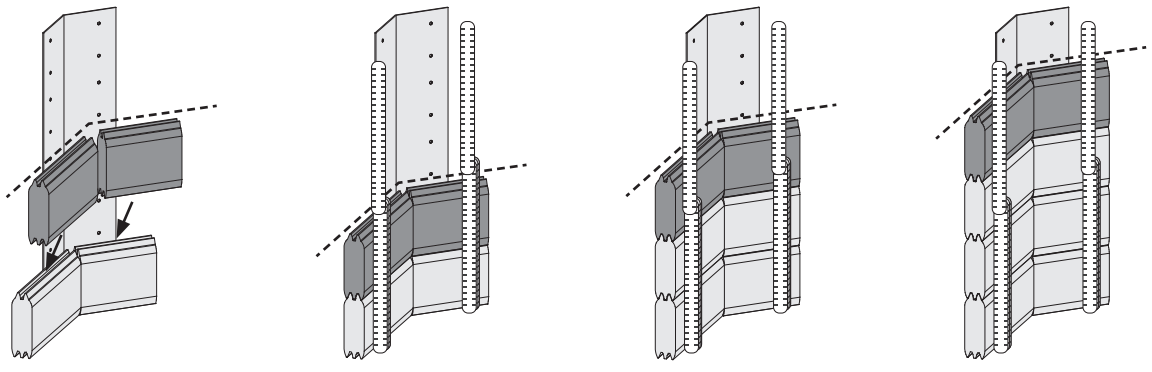

- Ø4 mm 6x35
- 220x

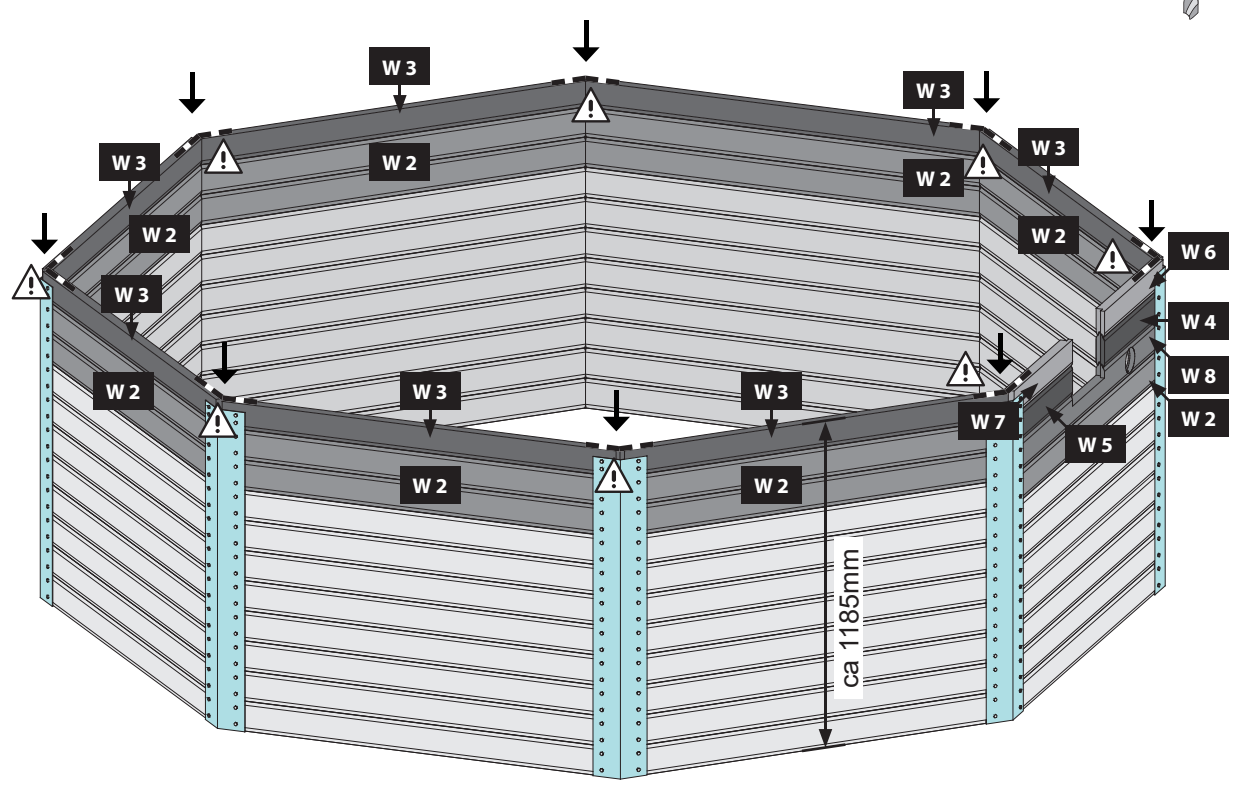
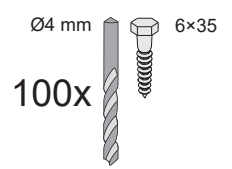
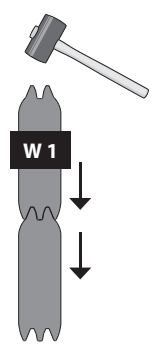
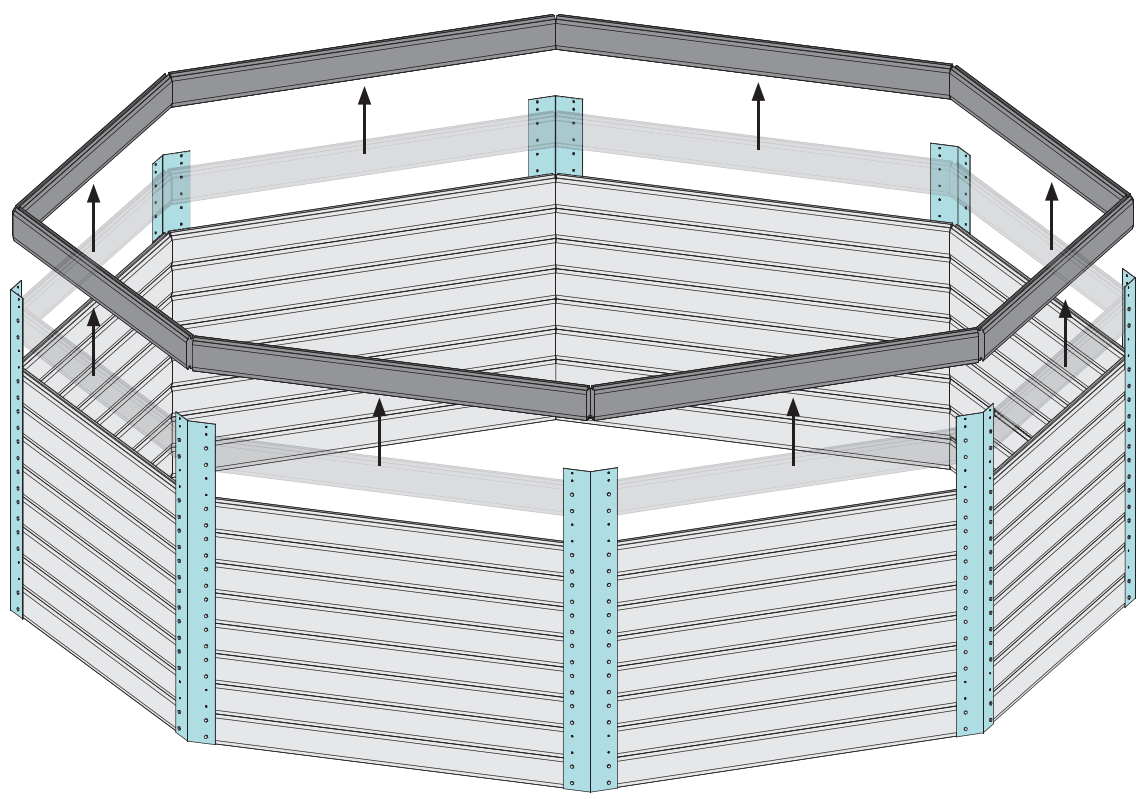

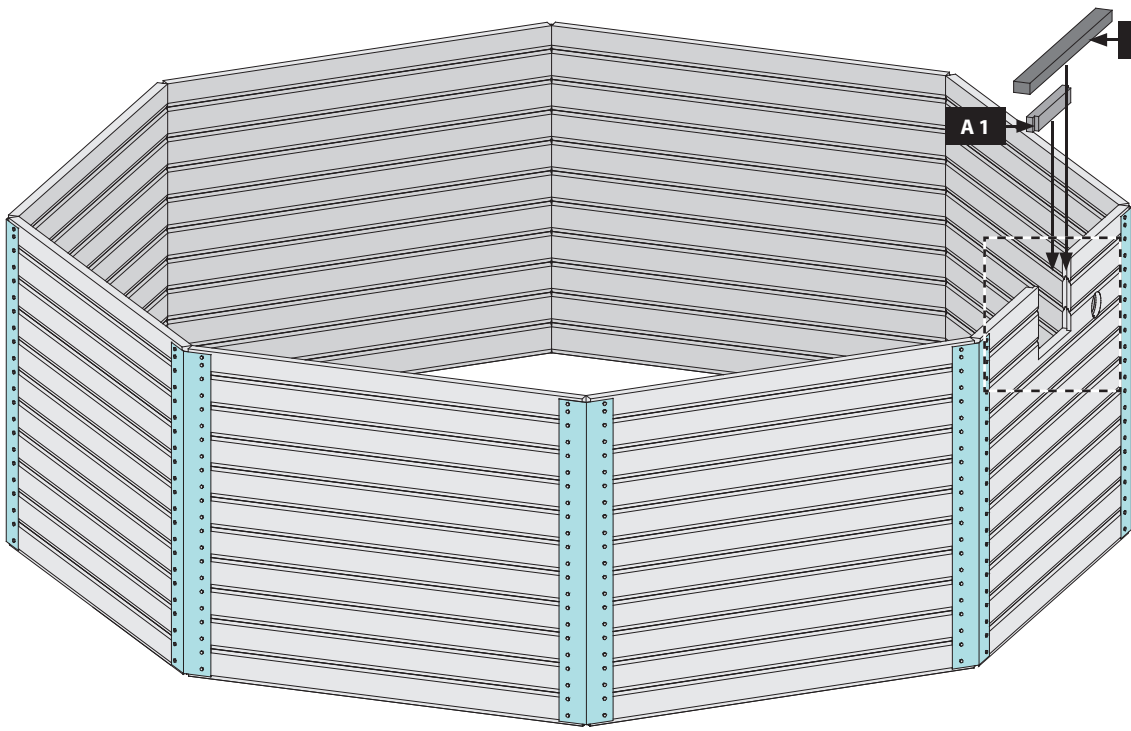

Ø5 mm
4x
6x80
VA

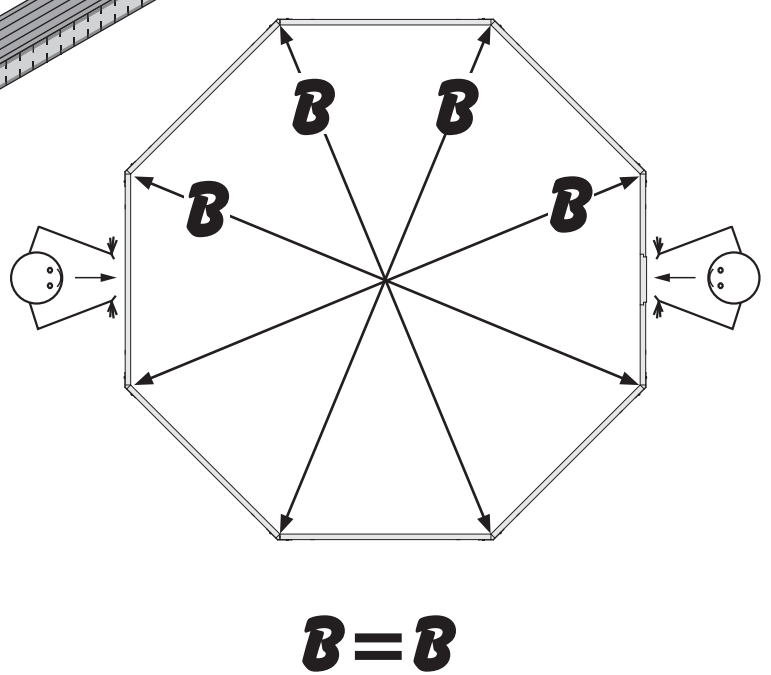
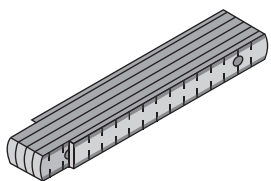
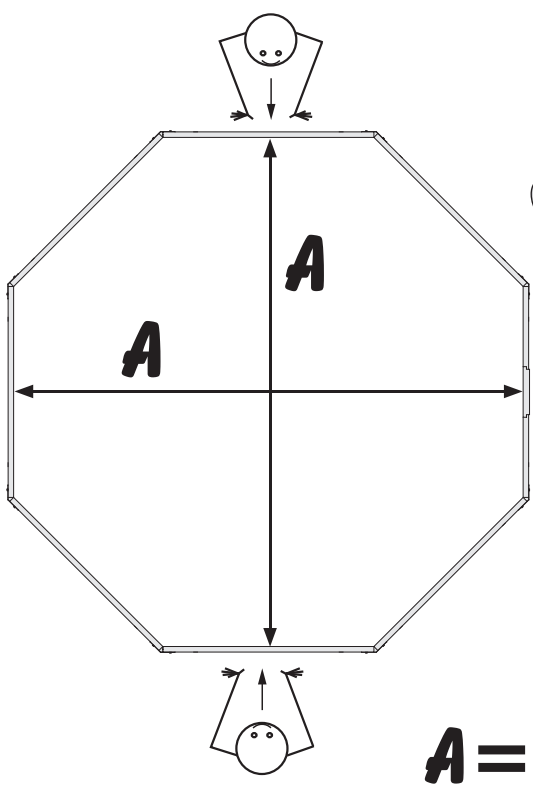
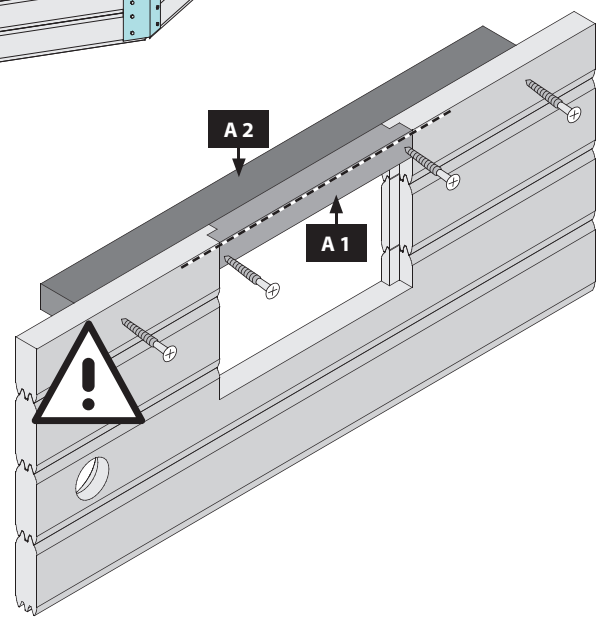
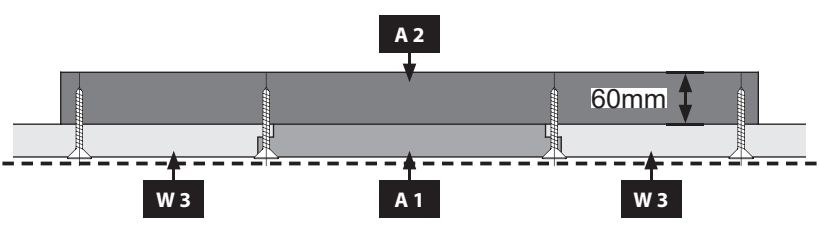
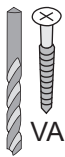

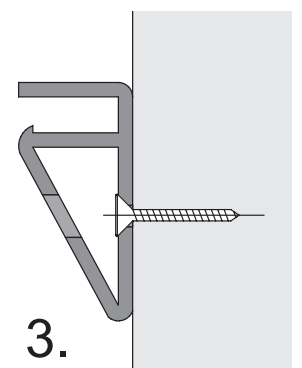
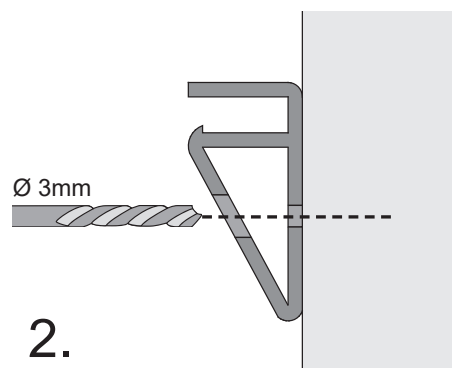
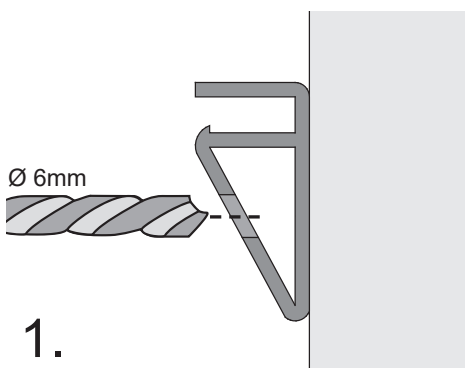
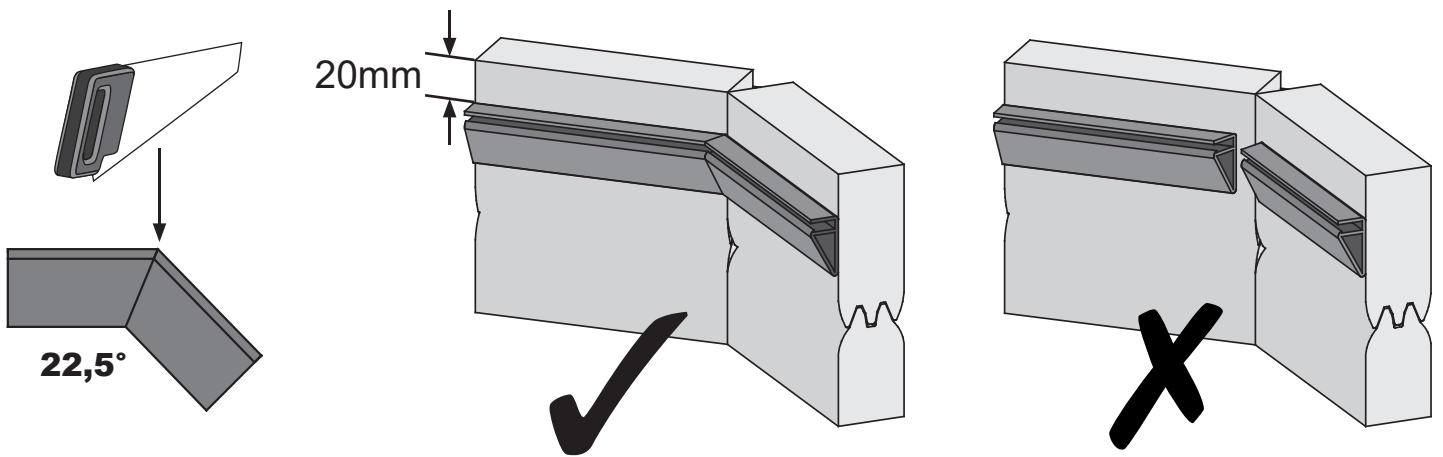
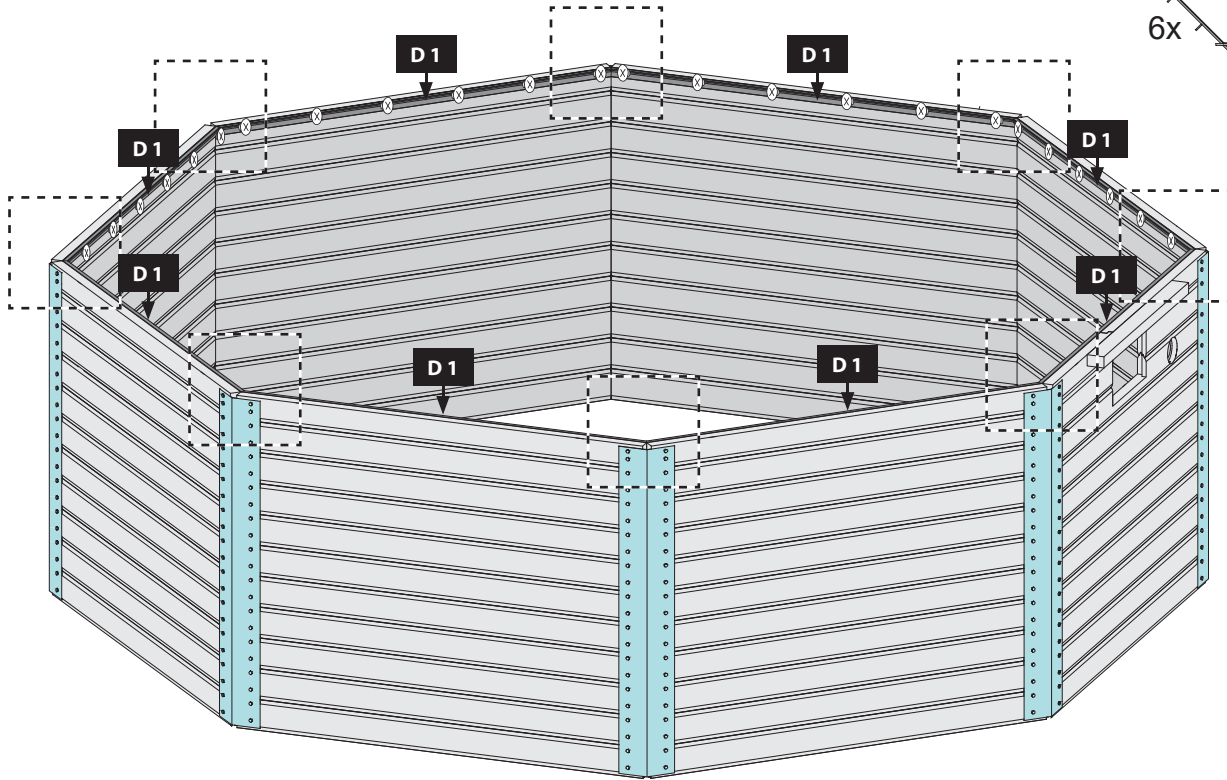
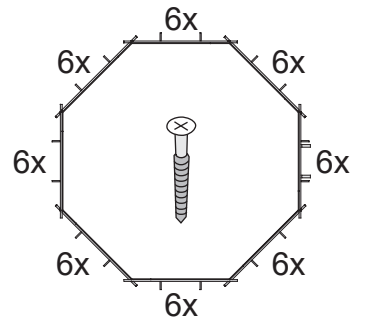
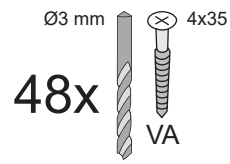

08

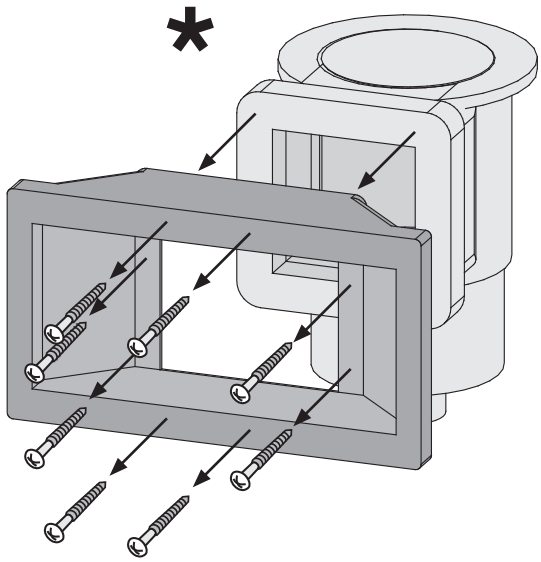

09

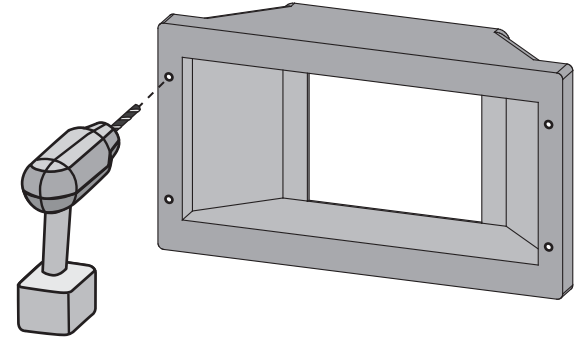

10

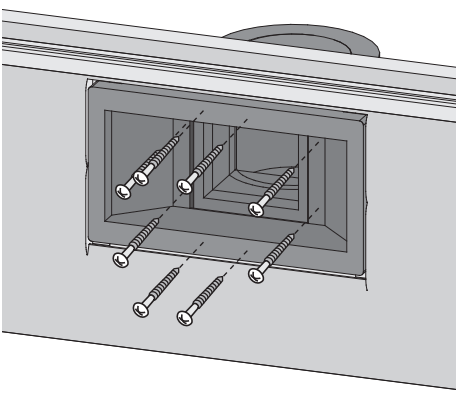
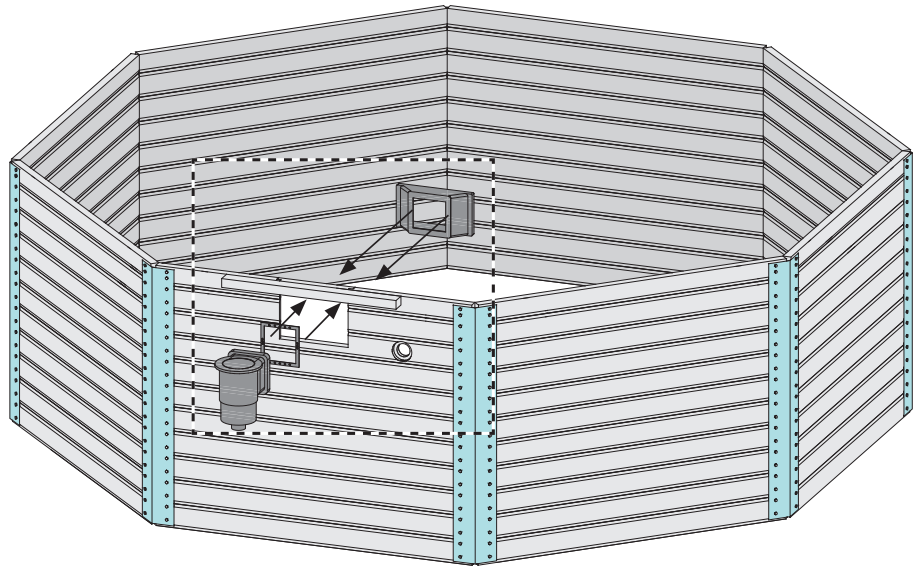

8x 5
VA

-  innen
-  Inside
-  à l'intérieur
-  inde på
-  binnen
-  dentro
-  dentro
-  uvnitř
-  znotraj

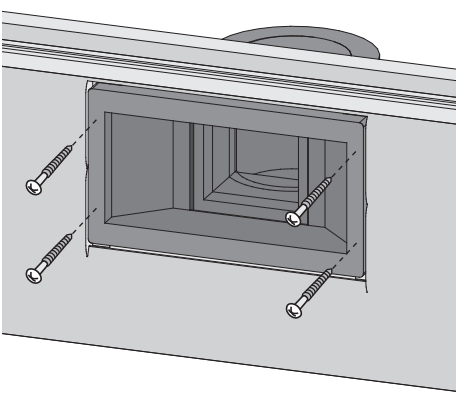
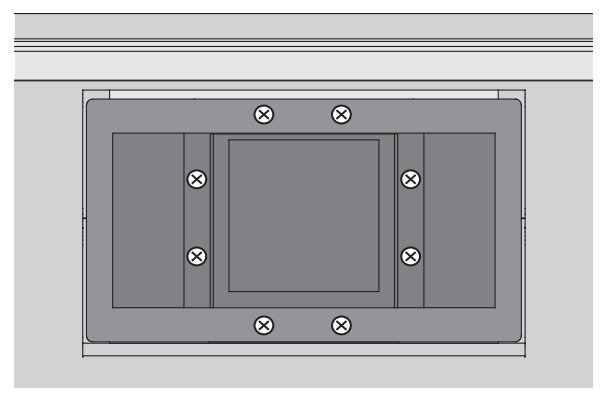

Ø3 mm 4x16
4x VA

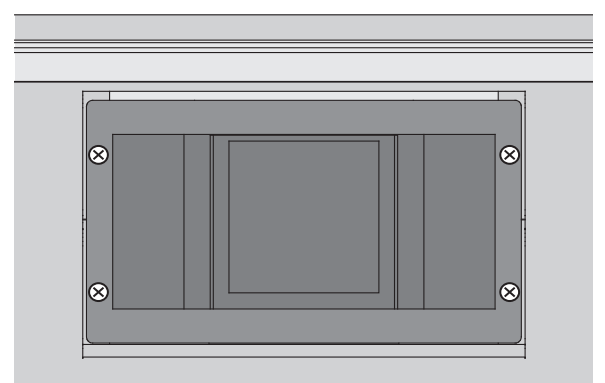

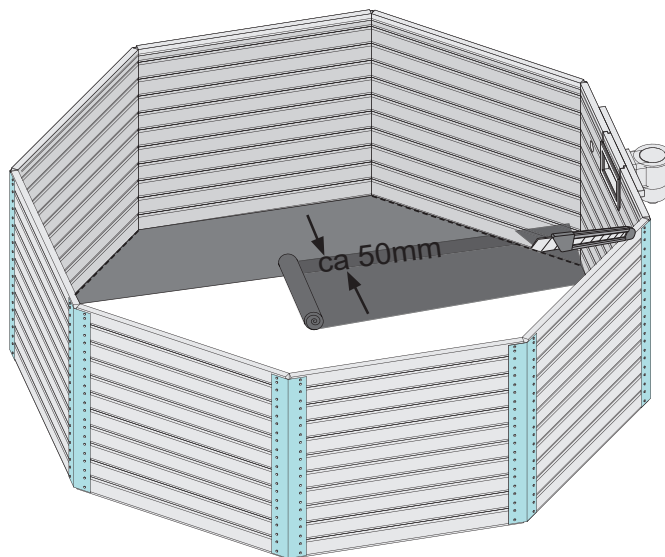
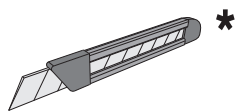
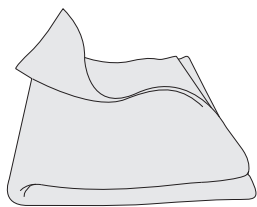

-  Vlies
-  Fleece
-  Membrane pour piscine
-  Vlies
-  Fleece
-  Vellón
-  Vello
-  Fleece
-  Fleece

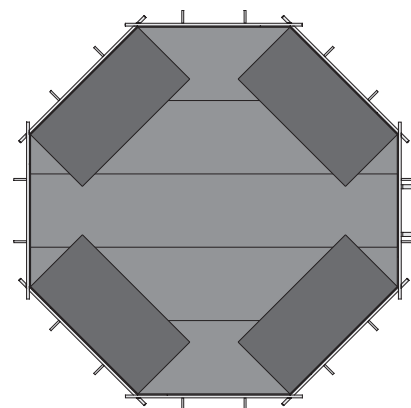
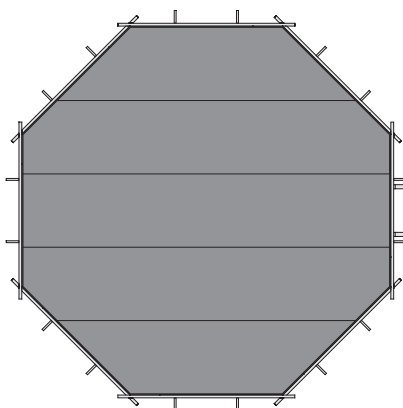

-  Poolfolie
-  Pool liner
-  Feutre de protection du sol
-  Zwembadfolie
-  Pulje liner
-  Lona de la piscina
-  Liner
-  Pool liner
-  Obloga za bazen

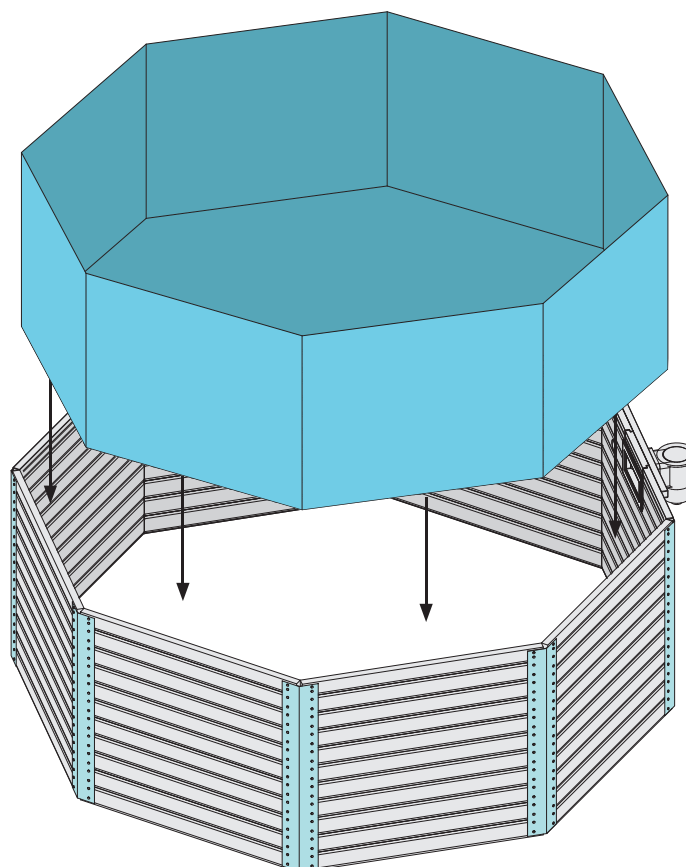

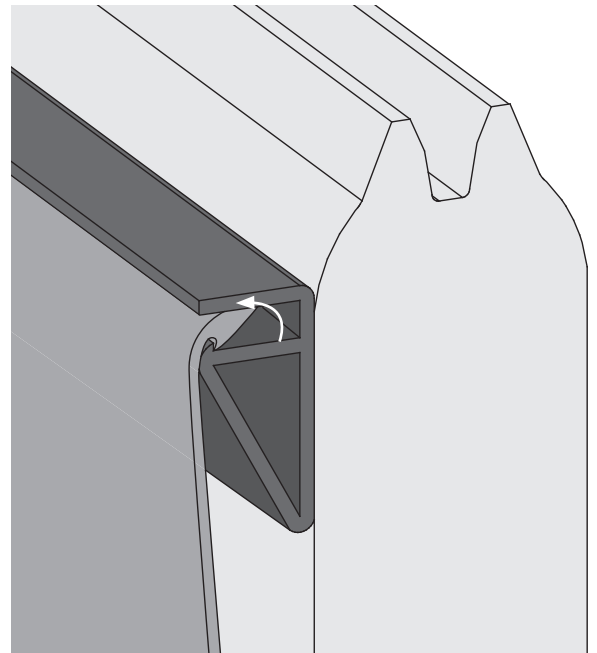
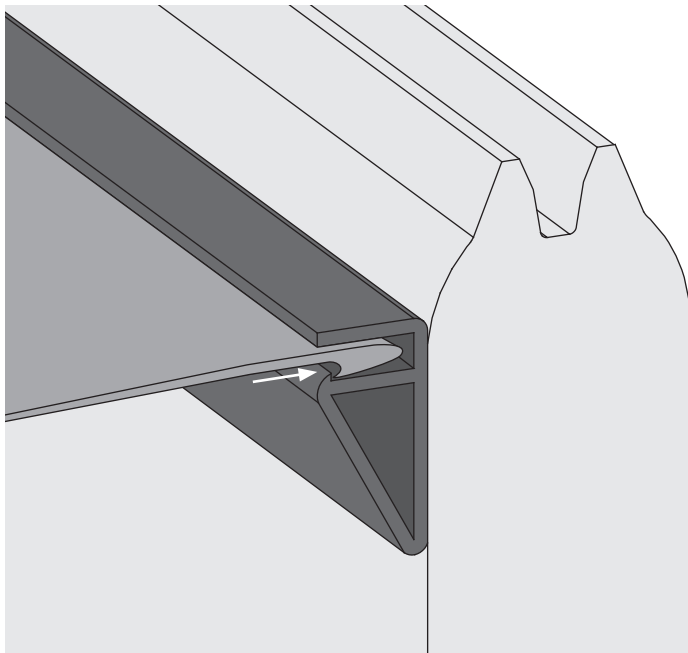
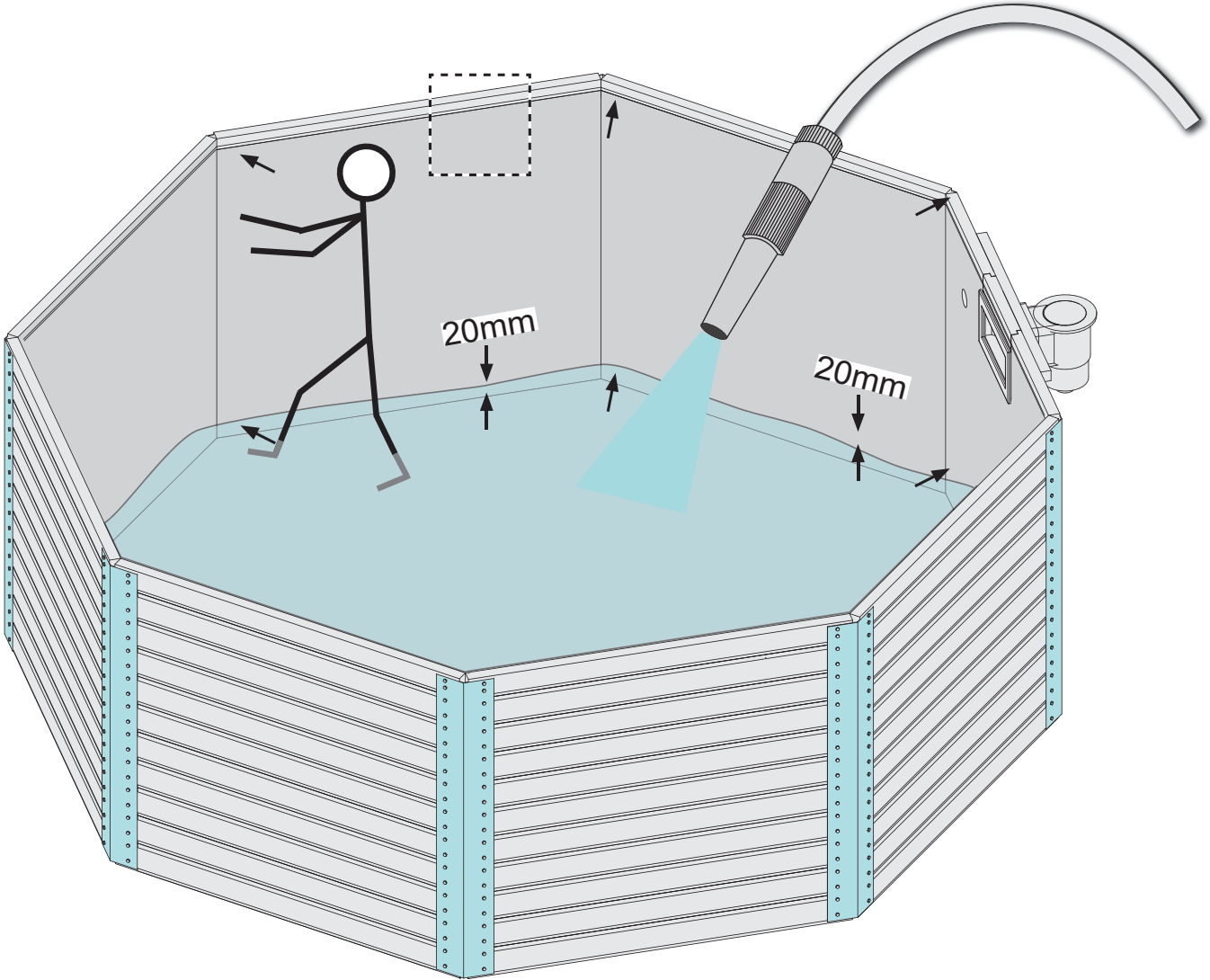
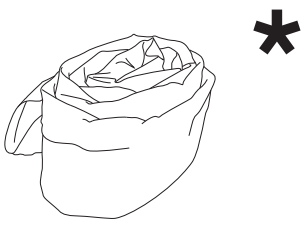

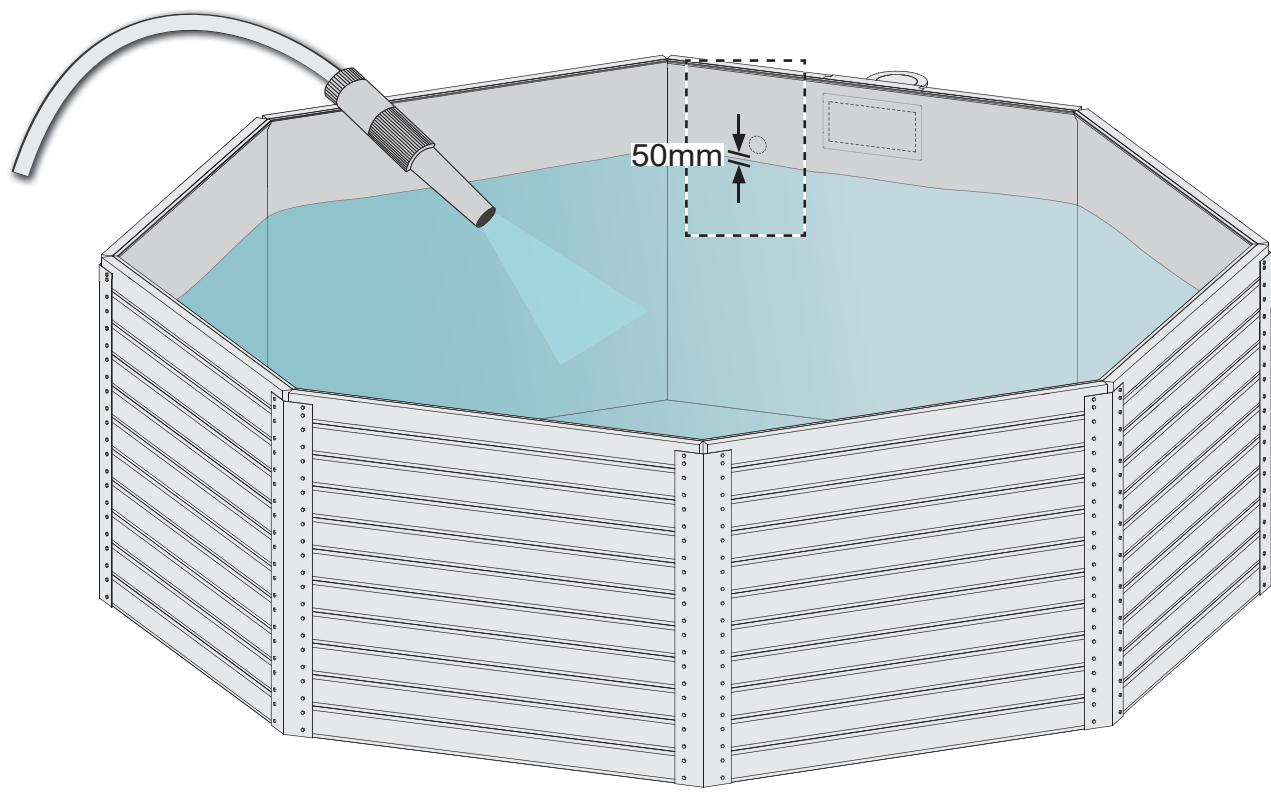

- Gewindedichtband
- Schroefdraadafdichtband
- Thread sealing tape
- Fil ruban d'étanchéité
- Cinta de sellado de rosca

- Nastro sigillante Discussione
- Závít páska
- Tråd forseglingsstapen
- Trak za tesnjenje navojev

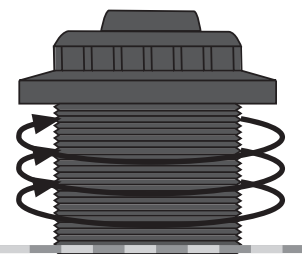

14.1

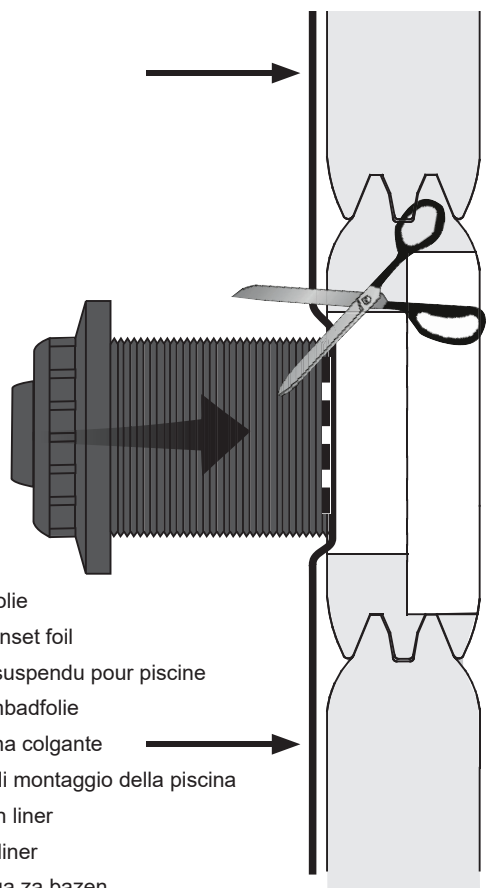

- Poolfolie
- Pool inset foil
- Film suspendu pour piscine
- Zwembadfolie
- Lámina colgante
- Telo di montaggio della piscina
- Bazén liner
- pulje liner
- Obloga za bazen

14.2

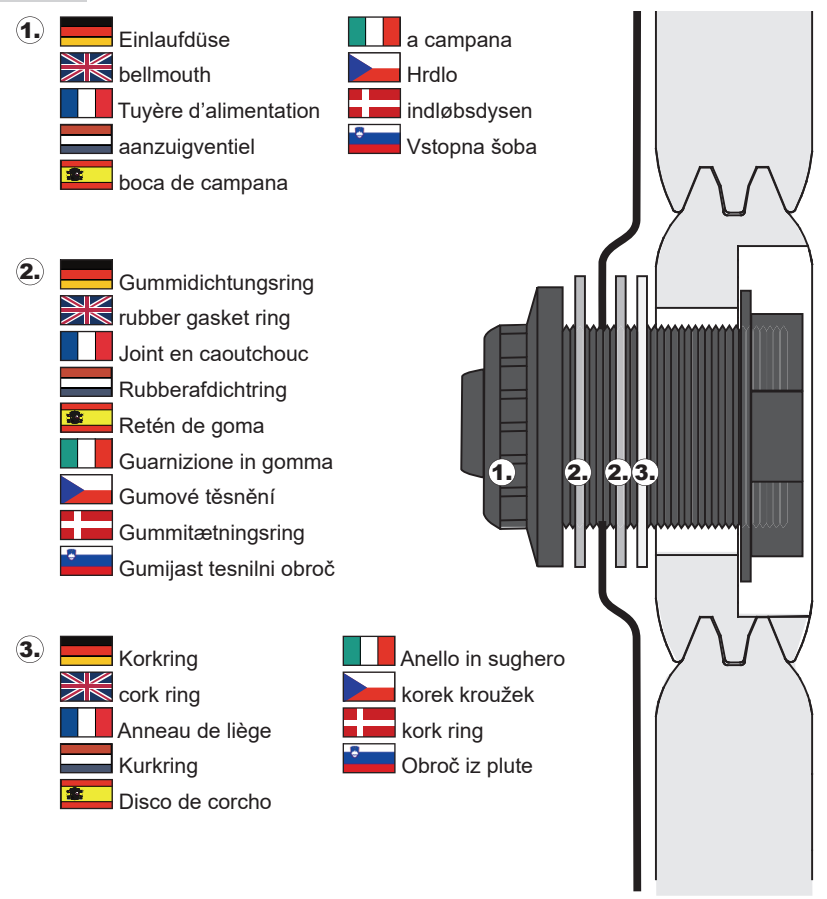

- 1.
- Einlaufdüse
 - bellmouth
 - Tuyère d'alimentation
 - aanzuigventiel
 - boca de campana

- a campana
- Hrdlo
- indløbsdysen
- Vstopna šoba

- 2.
- Gummidichtungsring
 - rubber gasket ring
 - Joint en caoutchouc
 - Rubberafdichtring
 - Retén de goma
 - Guarnizione in gomma
 - Gumové těsnění
 - Gummitætningsring
 - Gumijast tesnilni obroč

- 3.
- Korkring
 - cork ring
 - Anneau de liège
 - Kurkring
 - Disco de corcho

- Anello in sughero
- korek kroužek
- kork ring
- Obroč iz plute

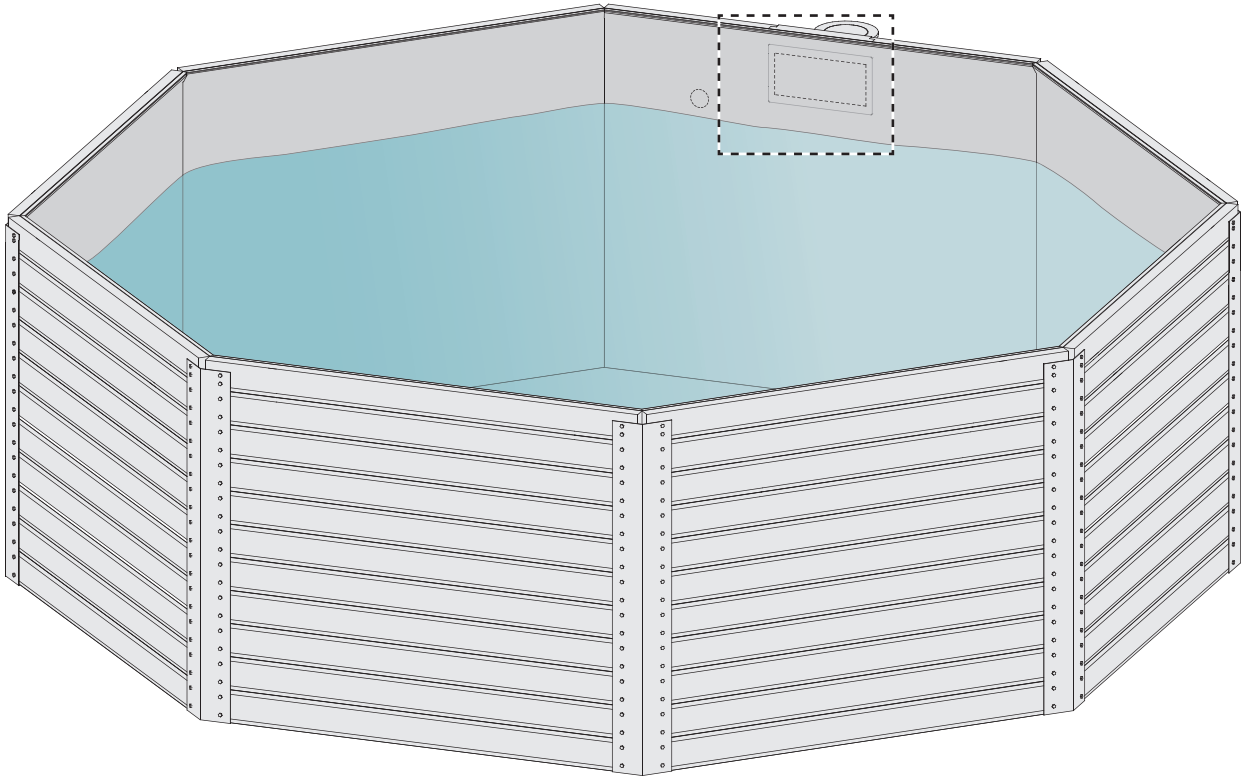

15.1-1 — 15.1-6

- 5  Bestand vom Skimmer
-  Inventory of the skimmer
-  Inventaire d'écumoire
-  Inventaris van de skimmer
-  Beholdning af skimmer
-  Inventario de skimmer
-  Inventario della scrematrice
-  Inventář skimmer
-  Zaloga iz skimerja

15.1-1

Ø3 mm 4x25
4x 5
VA

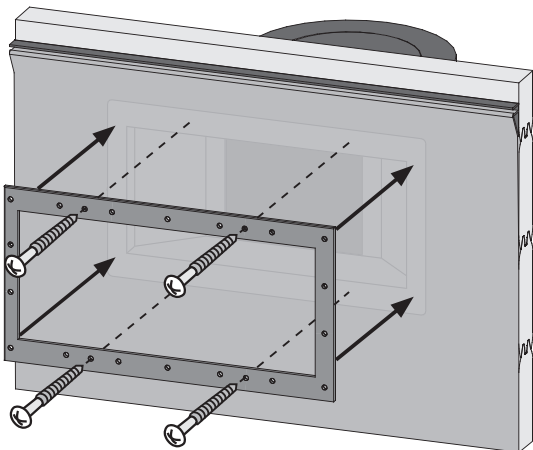

15.1-2

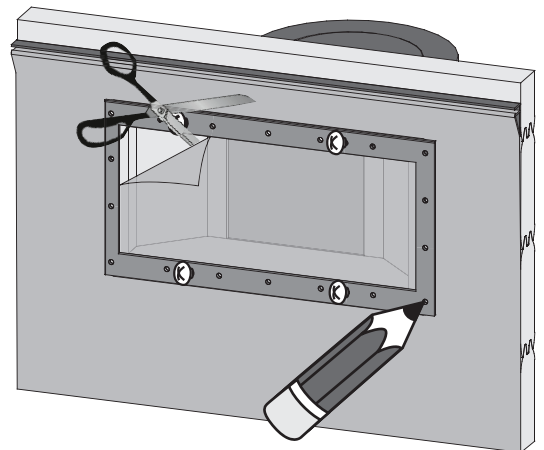

15.1-3

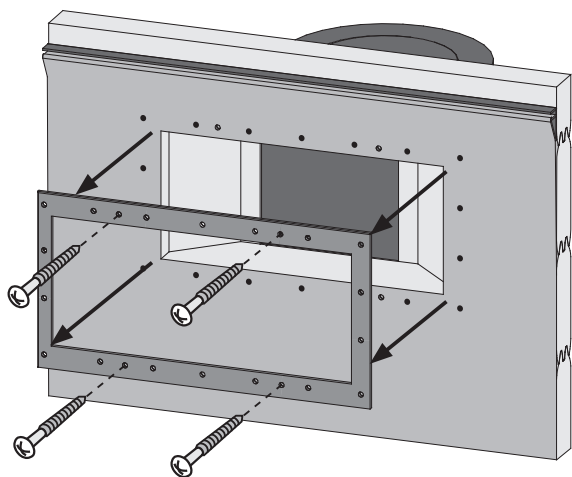

15.1-5

-  Abdeckung
-  deksel
-  cover
-  couverture
-  cubierta
-  copertura
-  víko
-  dæksel
-  Pokrov

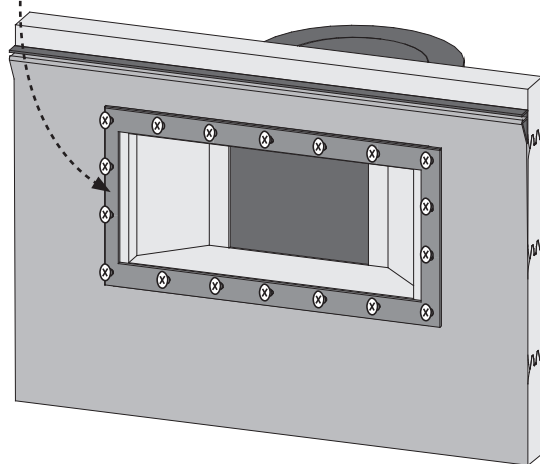
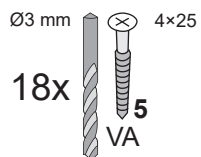

15.1-4

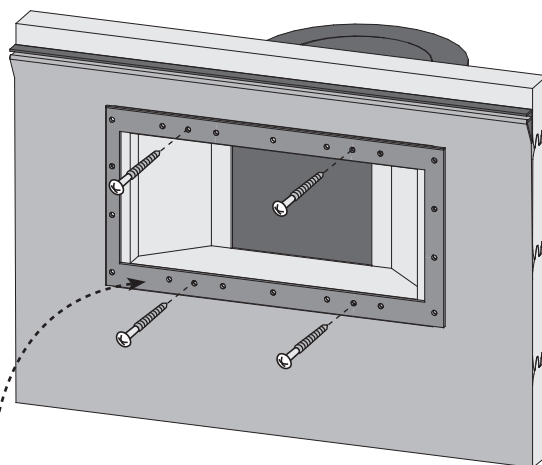
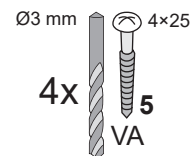

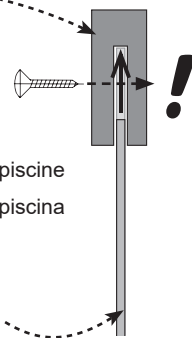

- | | |
|--|---|
|  Gummidichtung |  Poolfolie |
|  rubberen afdichting |  liner |
|  rubber seal |  pool liner |
|  joint en caoutchouc |  liner de la piscine |
|  sello de goma |  lona de la piscina |
|  guarnizione in gomma |  liner |
|  gumové těsnění |  pool liner |
|  gummitætning |  pulje folie |
|  Gumijasto tesnilo |  Obloga za bazen |



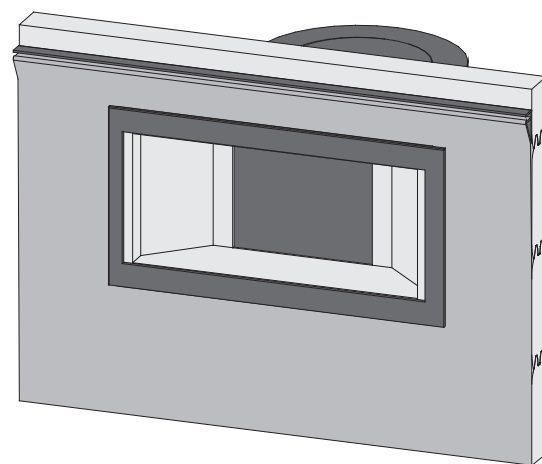

15.1-6





 Lieber Kunde, achten Sie auf die Aufbau-Variante!

 Geachte klant, let dan op de montage-versie!

 Dear customer, pay attention to the design variant!

 Cher client, attention à la version de montage!

 Estimado cliente, prestar atención a la versión montaje!

 Caro cliente, prestare attenzione alla versione montaggio!

 Vážený zákazníku, dbát na montážní verzi!

 Dragi kupec, preporučajte se, da ste izbrali pravo različico karoserije!

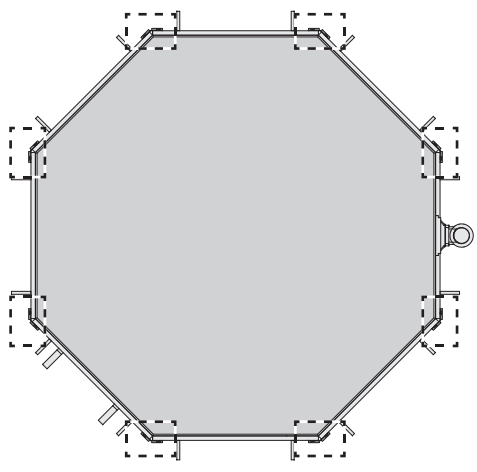
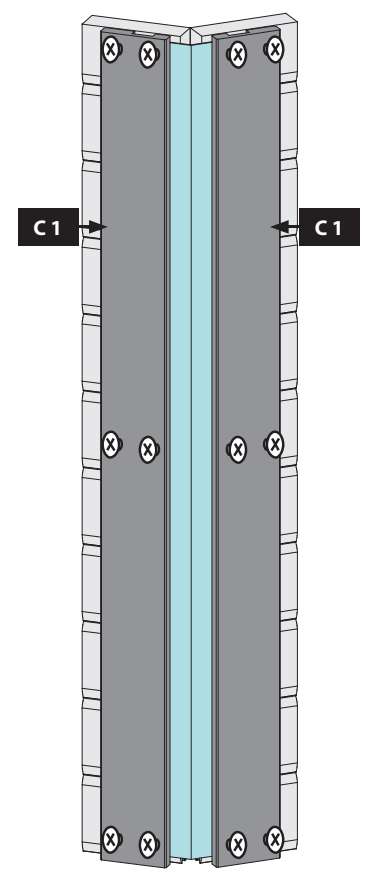
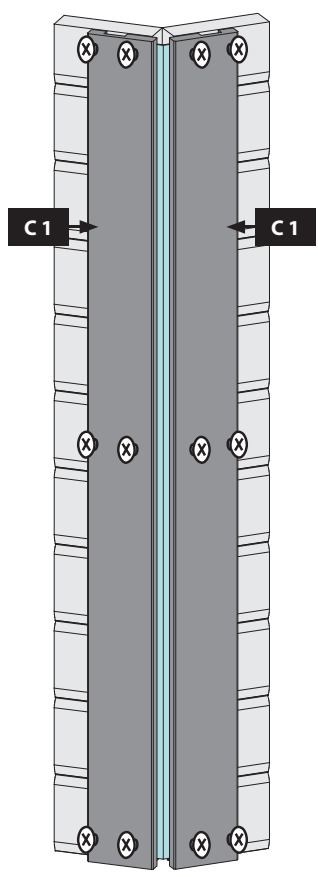
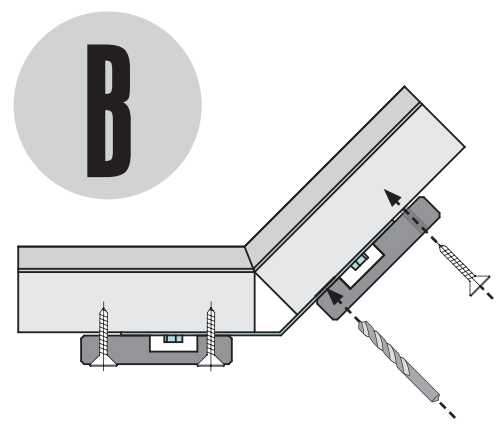
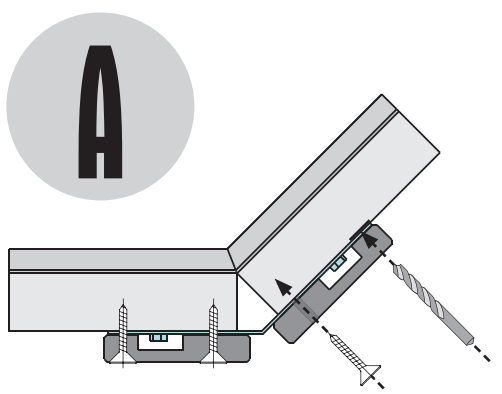
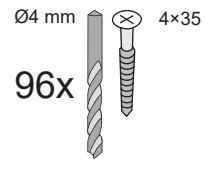
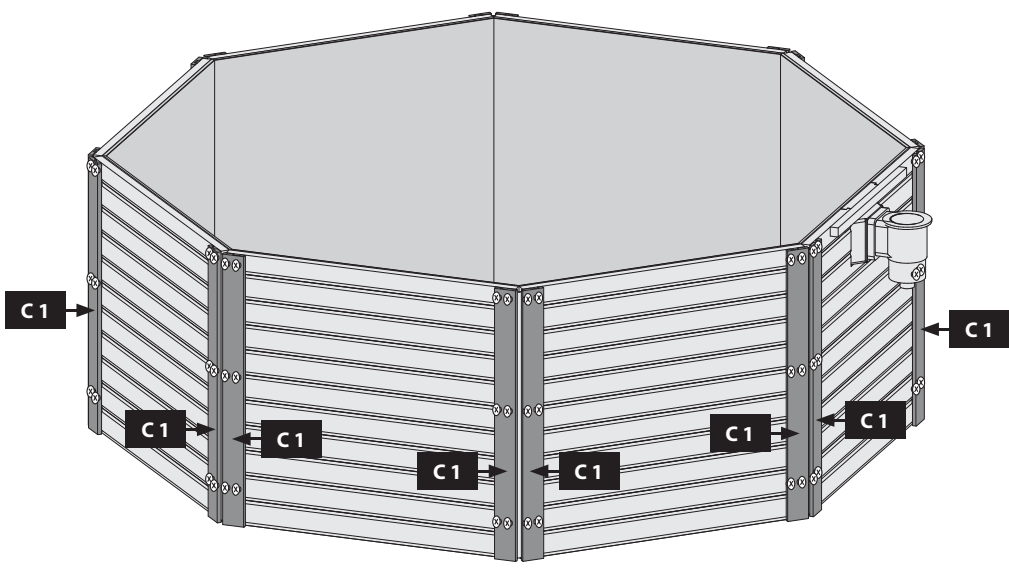

Ø4 mm 5x50

32x

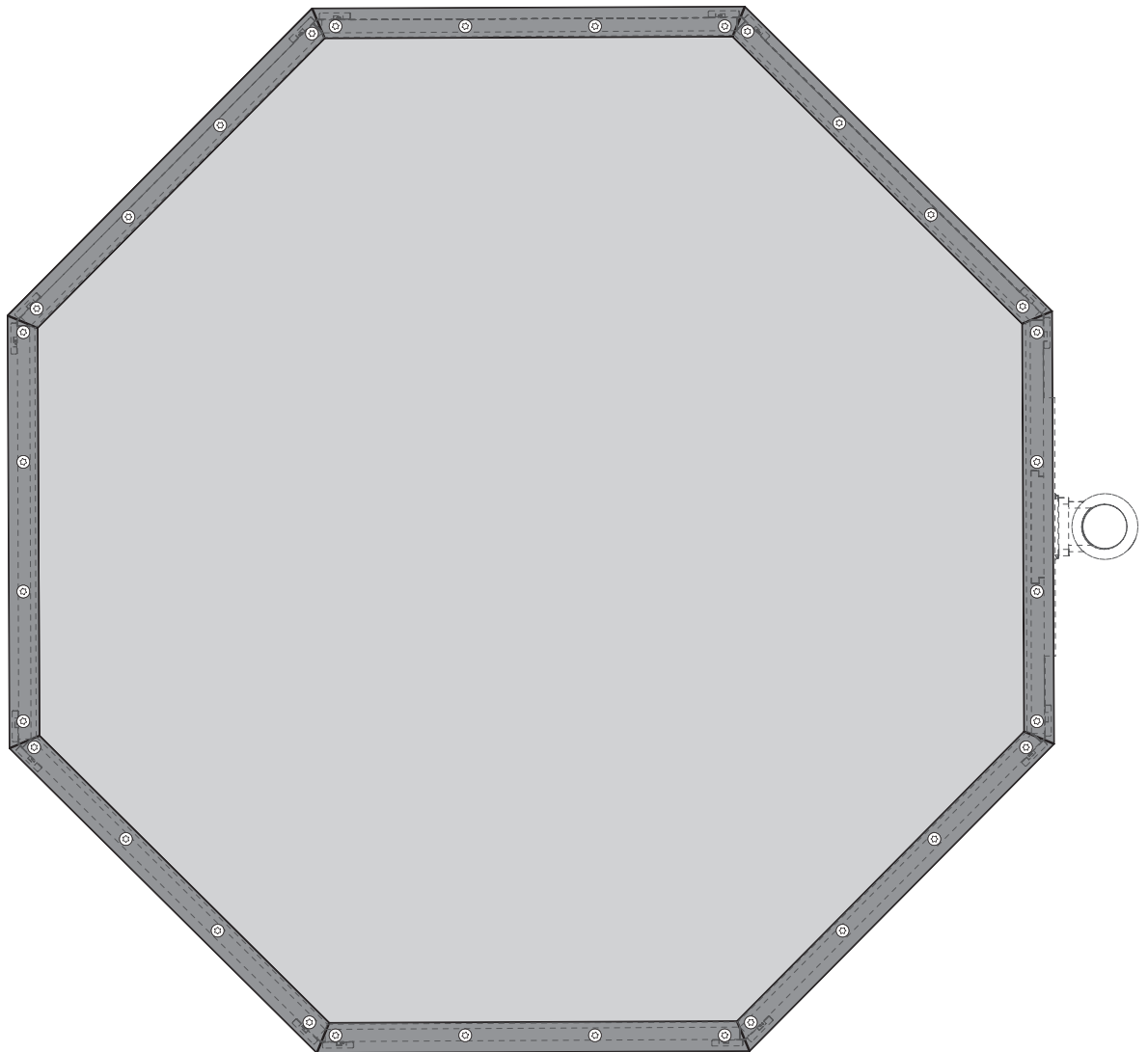
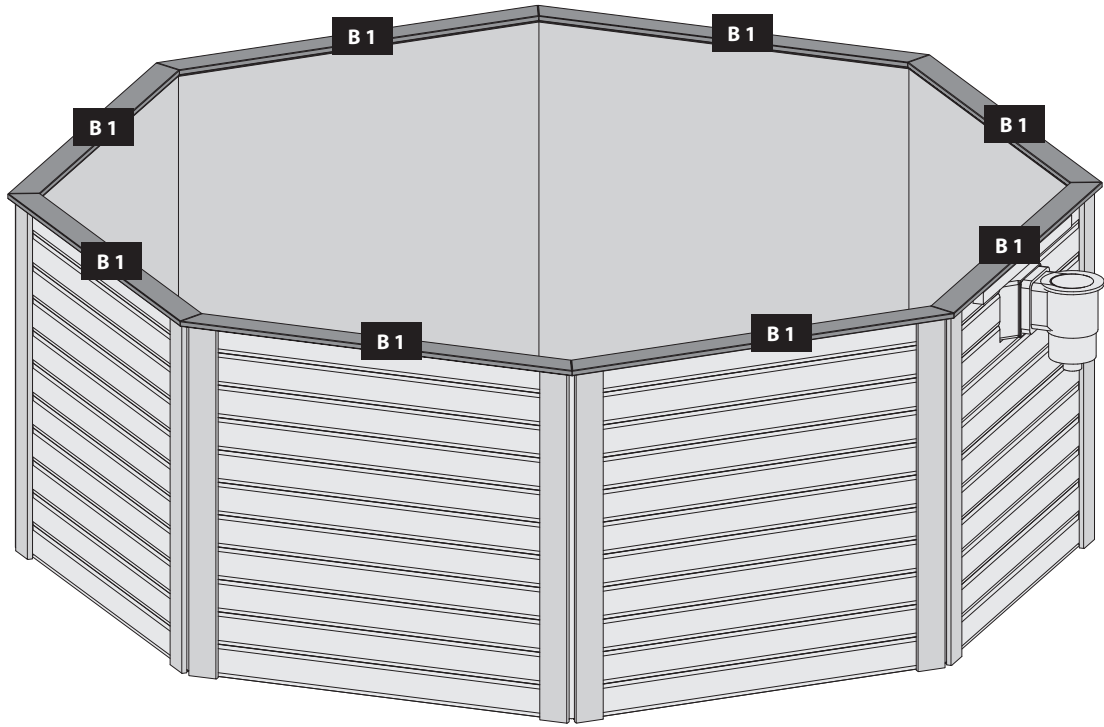
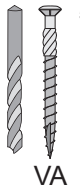



Produktthinweis



product Note



Remarque produit



product noteren



undersøgelse



producto Nota



Nota del prodotto



produkt Note



Opomba o izdelku



Poolpflege im Herbst und Winter

- Ist der Pool von vielen Pflanzen und Bäumen umgeben, muss dieser regelmäßig vom Laub befreit werden. Sind dennoch Blätter auf den Grund gesunken, müssen diese aufgrund von Schlammabildung zeitnah entfernt werden. Für den entsprechenden Schutz empfehlen wir die Winterabdeckfolie aus unserem Sortiment!
- Im Winter sollte der Pool nicht komplett entleert werden, da seitlicher Eisdruck entstehen kann. Der Wasserstand sollte bis unter die oberen Einläufe abgesenkt werden (ca 10-15 cm unter der Düse) und konstant auf diesem Niveau gehalten werden!
- Alle frostgefährdeten Leitungen und die Filteranlage vollständig entleeren, reinigen und trocken/frostsicher einlagern. Dies gilt für alle Zubehörteile aus Kunststoff und solche, die eingetaucht werden. (Das 6-Wege-Ventil der Filteranlage auf ENTLEREEN stellen. Weiter sollte der Sandfilterdeckel geöffnet werden, damit Luft in das System gelangt. Durch das Öffnen der Entleerungsschraube am Filterkessel und an der Filterpumpe kann das Wasser nun ablaufen.)
- Den Vorfilterdeckel der Filterpumpe abnehmen und Sieb reinigen.
- Alle Betriebschalter auf AUS stellen und den Netzschalter ausschalten. Die Sicherungen entfernen.



Pool maintenance in autumn and winter

- If the pool is surrounded by many plants and trees, it must be regularly removed from the leaves. nevertheless leaves are dropped to the ground, they must be removed promptly due to sludge formation. For the appropriate protection, we recommend the cover from our range!
- In winter, the pool should not be completely drained, because lateral ice pressure may arise. The water level should be lowered to below the upper inlets (About 10-15 cm below the nozzle) and held constant at this level are!
- Empty all frost exposed pipes and the filter system completely, clean and dry / store frost. This applies to all components of plastic and those which are immersed filters (The 6-way valve of the filter system to EMPTY. Next the sand filter cover should be opened to allow air into the system arrives. By opening the drain screw on the filter vessel and the filter pump the water can run now.)
- The preliminary filter, the filter pump and then clean sieve.
- Set all the power switch off and disconnect the mains cable. Remove the fuses.



Entretien de la piscine à l'automne et l'hiver

- Si la piscine est entourée par de nombreuses plantes et des arbres, il doit être régulièrement retiré des feuilles. néanmoins les feuilles sont tombées à terre, ils doivent être rapidement retirés en raison de la formation de boues. Pour la protection appropriée, nous recommandons la couverture de notre gamme!
- En hiver, la piscine ne doit pas être complètement vidé, parce que la pression de la glace latérale peut se poser. Le niveau d'eau devrait être abaissé au-dessous des prises supérieures (environ 10-15 cm en dessous de la buse) être et maintenue constante à ce niveau!
- Videz les tuyaux de gel exposés et complètement le système de filtre, propre et sec / magasin gel. Cela vaut pour tous les éléments de plastique et ceux qui sont immergés. (Placez la vanne 6 voies du système de filtre à VIDER. Ensuite, le couvercle du filtre à sable doit être ouvert pour permettre à l'air dans le système. En ouvrant la vis de vidange sur la cuve de filtre et la pompe de filtration, l'eau peut maintenant procéder.)
- Le filtre préliminaire, la pompe à filtre et tamis puis nettoyer.
- Réglez tout l'appareil hors tension et débranchez le câble d'alimentation. Retirer les fusibles.



Zwembad onderhoud in de herfst en winter

- Als het zwembad is omgeven door veel planten en bomen, het moet regelmatig worden verwijderd uit de bladeren. Toch bladeren viel op de grond, moeten zij onmiddellijk worden verwijderd als gevolg van slibvorming. Voor de juiste bescherming, raden we het deksel van ons assortiment!
- In de winter is het zwembad mag niet worden helemaal leeg, omdat zijdelingse ijs druk kunnen ontstaan. Het waterniveau worden verlaagd tot onder de bovenste inname (ongeveer 10-15 cm onder het mondstuk) en constant gehouden op dit niveau!
- Leeg alle vorst blootgesteld leidingen en het filter systeem volledig, schoon en droog / store vorst. Dit geldt voor alle onderdelen van kunststof en die zijn ondergedompeld. (Plaats de 6-weg klep van het filtersysteem te legen. Vervolgens wordt de zandfilter kap moet worden geopend om lucht in het systeem. Door het openen van de afvoer schroef op de filter vat en de filter pomp, het water kan nu verder gaan.)
- Het voorfilter, het filter pomp en vervolgens schoon zeef.
- Zet de stroom uit te schakelen en de stekker uit het netsnoer. Verwijder de zekeringen.



Mantenimiento de la piscina en otoño e invierno

- Si la piscina está rodeada de muchas plantas y árboles, se debe retirarse periódicamente las hojas. sin embargo, las hojas se dejan caer al suelo, deben ser eliminado rápidamente debido a la formación de lodos. Para la protección adecuada, se recomienda la tapa de nuestra gama!
- En invierno, la piscina no debe ser completamente agotada, porque puede surgir la presión del hielo lateral. El nivel del agua debe ser bajado por debajo de las ingestas superiores (unos 10-15 cm por debajo de la boquilla) y se mantuvo constante a este nivel!
- Vaciar todas las tuberías heladas expuesta y el sistema de filtro por completo, limpio y seco / tienda de heladas. Esto se aplica a todos los componentes de plástico y los que están inmersos. (Coloque la válvula de 6 vías del sistema de filtro en VACÍO. A continuación, la tapa del filtro de arena debe ser abierta para permitir que el aire en el sistema. Con la apertura de la válvula de drenaje en el recipiente del filtro y la bomba del filtro, el agua puede ahora proceder.)
- El filtro previo, la bomba de filtro y tamiz luego limpia.
- fijado todo el interruptor de encendido y desconecte el cable de red. Retire los fusibles.



Produktinweis



product Note



Remarque produit



product noteren



undersøgelse



producto Nota



Nota del prodotto



produkt Note



Opomba o izdelku



Manutenzione della piscina in autunno e inverno

- Se la piscina è circondata da molte piante e alberi, deve essere rimosso regolarmente dalle foglie. tuttavia le foglie sono caduti a terra, essi devono essere rimosso prontamente a causa della formazione di fanghi. Per la protezione del caso, si consiglia la copertura della nostra gamma!
- In inverno, la piscina non dovrebbe essere completamente scarica, perché la pressione del ghiaccio laterale può sorgere. Il livello dell'acqua dovrebbe essere abbassato al di sotto le prese superiori (circa 10-15 cm sotto l'ugello) essere e mantenuta costante a questo livello!
- Svuotare tutti i tubi di gelo a vista e il sistema di filtraggio completamente, pulito ed asciutto / store gelo. Questo vale per tutti i componenti in plastica e quelli che sono immersi. (Posizionare la valvola 6 vie del sistema di filtrazione a vuoto. Successivamente il coperchio del filtro sabbia deve essere aperto per consentire aria nel sistema. Aprendo la vite di scarico sulla nave filtro e la pompa del filtro, l'acqua può ora procedere.)
- Il filtro preliminare, la pompa filtro e vaglio quindi pulita.
- Impostare tutto il potere spegnere e scollegare il cavo di alimentazione. Rimuovere i fusibili.



Údržba na podzim av zimě bazén

- Pokud je bazén obklopen mnoha rostlin a stromů, musí být pravidelně odstraňovány z listů. Nicméně listy jsou spadl na zem, musí být neprodleně odstranit v důsledku tvorby kalu. Za vhodnou ochranou, doporučujeme kryt z naší nabídky!
- V zimě, bazén by neměly být zcela vypuštěny, protože mohou vzniknout boční tlak ledu. Hladina vody by měla být snížena pod horními vstupy (cca 10 až 15 cm pod tryskou), se udržuje konstantní, a na této úrovni!
- Prázdňá všechny mráz vystavení potrubí a filtrační systém zcela čistý a suchý / sklad mrazu. To platí pro všechny součásti z plastů a ty, které jsou ponořeny. (Umístěte 6-cestný ventil filtračního systému na prázdný. Dále je kryt pískový filtr by měl být otevřený, aby vzduchu do systému. Otevřením vypouštěcího šroubu na filtrační nádoby a filtrační čerpadla, voda může nyní pokračovat.)
- Předběžný filtr, filtr čerpadla a pak čisté síto.
- Nastavte všechny hlavní vypínač a odpojte napájecí kabel. Vyjměte pojistky.





Vzdrževanje bazena jeseni in pozimi

- Če je bazen obdan z veliko rastlinami in drevesi, je treba listje redno odstranjevati. Če pa se je listje spustilo na dno, ga je treba zaradi nastajanja blata odstraniti takoj. Za ustrezno zaščito priporočamo zimsko prekrivno folijo iz naše ponudbe!
- Pozimi bazena ne smete popolnoma izprazniti, saj lahko nastane bočni pritisk ledu. Vodno gladino je treba spustiti pod zgornje dovode (približno 10-15 cm pod šobo) in jo na tej ravni tudi obdržati!
- Popolnoma izpraznite in očistite vse cevi in filtrirni sistem, ki jim grozi zmrzal, ter jih shranite na suhem/mrzlo varnem mestu. To velja za vse plastične dodatke in ki so potopljeni. (Šeststopenjski ventil filtrirnega sistema nastavite na EMPTY. Odprite tudi pokrov peščenega filtra, da omogočite vstop zraka v sistem, Vodo lahko zdaj izpraznite tako, da odprete izpustni čep na filtrirni posodi in črpalki filtra).
- Odstranite pokrov predfiltra na filtrirni črpalki in očistite filter.
- Nastavite vsa stikala za upravljanje v položaj OFF in izklopite omrežno stikalo. Odstranite varovalke.

 Produkthinweis
 product Note
 Remarque produit

 product noteren
 undersøgelse
 producto Nota

 Nota del prodotto
 produkt Note
 Opomba o izdelku

